

SECURITIES AND EXCHANGE COMMISSION
WASHINGTON, D.C. 20549

FORM 10-K
FOR ANNUAL AND TRANSITION REPORTS
PURSUANT TO SECTIONS 13 OR 15(d) OF THE
SECURITIES EXCHANGE ACT OF 1934

ANNUAL REPORT PURSUANT TO SECTION 13 OR 15(d) OF THE SECURITIES EXCHANGE ACT OF 1934

For the fiscal year ended March 31, 2003

OR

TRANSITION REPORT PURSUANT TO SECTION 13 OR 15(d) OF THE SECURITIES EXCHANGE ACT OF 1934

For the Transition Period from _____ to _____

Commission file number 0-19672

American Superconductor Corporation

(Exact Name of Registrant as Specified in Its Charter)

Delaware

(State or other jurisdiction
of incorporation or organization)

Two Technology Drive
Westborough, Massachusetts
(Address of Principal Executive Offices)

04-2959321

(IRS Employer
Identification Number)

01581
(Zip Code)

Registrant's telephone number, including area code: (508) 836-4200

Securities registered pursuant to Section 12(b) of the Act: None

Securities registered pursuant to Section 12(g) of the Act: Common Stock, \$.01 par value

Indicate by check mark whether the Registrant: (1) has filed all reports required to be filed by Section 13 or 15(d) of the Securities Exchange Act of 1934 during the preceding 12 months (or for such shorter period that the Registrant was required to file such reports), and (2) has been subject to such filing requirements for the past 90 days.

Yes No

Indicate by check mark if disclosure of delinquent filers pursuant to Item 405 of Regulation S-K is not contained herein, and will not be contained, to the best of Registrant's knowledge, in definitive proxy or information statements incorporated by reference in Part III of this Form 10-K or any amendment to this Form 10-K.

Indicate by check mark whether the Registrant is an accelerated filer (as defined in Exchange Act Rule 12b-2). Yes No

On September 30, 2002, the aggregate market value of voting and non-voting Common Stock held by nonaffiliates of the Registrant was \$54,167,756 based on the closing price of the Common Stock on the NASDAQ National Market on September 30, 2002.

The number of shares of Common Stock outstanding as of June 20, 2003 was 21,343,720.

DOCUMENTS INCORPORATED BY REFERENCE

Document

Form 10-K Part

Definitive Proxy Statement with respect to the Annual Meeting of Stockholders for the fiscal year ended March 31, 2003, to be filed with the Securities and Exchange Commission no later than July 29, 2003

Part III

TABLE OF CONTENTS

<u>Item</u>		<u>Page</u>
	<u>Part I</u>	
1.	Business	2
2.	Properties	26
3.	Legal Proceedings	26
4.	Submission of Matters to a Vote of Security Holders	26
	<u>Part II</u>	
5.	Market for Registrant’s Common Stock and Related Stockholder Matters	29
6.	Selected Financial Data	29
7.	Management’s Discussion and Analysis of Financial Condition and Results of Operations	30
7A.	Quantitative and Qualitative Disclosures About Market Risk	30
8.	Financial Statements and Supplementary Data	30
9.	Changes and Disagreements with Accountants on Accounting and Financial Disclosure	30
	<u>Part III</u>	
10.	Directors and Executive Officers of the Registrant	31
11.	Executive Compensation	31
12.	Security Ownership of Certain Beneficial Owners and Management and Related Stockholder Matters	31
13.	Certain Relationships and Related Transactions	31
14.	Controls and Procedures	31
	<u>Part IV</u>	
15.	Exhibits, Financial Statement Schedules and Reports on Form 8-K	32

This Annual Report on Form 10-K contains forward-looking statements within the meaning of Section 21E of the Securities Exchange Act of 1934, as amended. For this purpose, any statements contained herein that relate to future events or conditions, including without limitation, the statements under “Item 1. Business” and “Item 7. Management’s Discussion and Analysis of Financial Condition and Results of Operations” and located elsewhere herein regarding industry prospects and the Company’s prospective results of operations or financial position, may be deemed to be forward-looking statements. Without limiting the foregoing, the words “believes,” “anticipates,” “plans,” “expects,” and similar expressions are intended to identify forward-looking statements. Such forward-looking statements represent management’s current expectations and are inherently uncertain. The important factors discussed below under the caption “Management’s Discussion and Analysis of Financial Conditions and Results of Operations — Future Operating Results,” among others, could cause actual results to differ materially from those indicated by forward-looking statements made herein and presented elsewhere by management from time to time. Any such forward-looking statements represent management’s estimates as of the date of this Annual Report on Form 10K. While the Company may elect to update such forward-looking statements at some point in the future, it disclaims any obligation to do so, even if subsequent events cause its views to change. These forward-looking statements should not be relied upon as representing the Company’s views as of any date subsequent to the date of this Annual Report on Form 10-K.

[Table of Contents](#)

Item 1. Business

Overview

American Superconductor Corporation (AMSC) is a leading electricity solutions company. We develop solutions and manufacture products to dramatically improve the cost, efficiency and reliability of systems that generate, deliver and use electric power. Products from AMSC include high temperature superconductor (HTS) wire for electric power, transportation, medical and industrial processing applications; HTS motors and generators for ship propulsion, as well as synchronous condensers for transmission grid reliability; and advanced power electronic and HTS systems that ensure the quality and reliability of electricity for residential, commercial and industrial customers. Our current and planned products are sold or planned to be sold to electrical equipment manufacturers, industrial power users, builders of ships that utilize electric drives and businesses that produce and deliver electric power. Our products, and those sold by others who incorporate our products, can:

- Dramatically increase the reliability and power transfer capacity of power transmission and distribution grids;
- Substantially improve the quality of electric power delivered to manufacturing plants;
- Greatly reduce the manufacturing and operating costs of primary electrical equipment, including generators and motors;
- Significantly reduce the size and weight of power cables, motors, generators, and other electric power equipment; and
- Conserve energy resources used to produce electricity, such as oil, gas and coal, by more efficiently conducting and converting electricity into useful forms with environmentally friendly technology.

We believe there will be significant market demand for our products because of the following factors:

- Demand for electric power continues to grow on a global basis;
- The power grids in the U.S. and in many developed nations face severe constraints in adequately and safely delivering the amounts of power demanded by electric power users;
- Power reliability and power quality are increasingly important as economies transition to computerized and digitized systems;
- U.S. domestic policy is now addressing the need to upgrade the transmission and distribution grid as part of an effective long-term national energy policy; and
- Environmental threats from global industrialization and population growth continue to influence nations to encourage environmentally friendly power technologies.

Superconductor Technology

A superconductor is a perfect conductor of electricity. It carries direct current with 100 percent efficiency because no energy is dissipated by resistive heating. Direct current in a superconducting loop can flow undiminished forever. Superconductors can also conduct alternating current but with some slight loss of energy.

Superconductor materials lose all resistance to the flow of direct electrical current and nearly all resistance to the flow of alternating electrical current when they are cooled below a critical temperature. The critical temperature is different for each superconductor material. Superconductor materials, including both HTS materials and low temperature superconductor (LTS) materials, need to be cooled to very low temperatures to act as superconductors. Wires made with HTS material typically operate at temperatures that are five to 20 times

[Table of Contents](#)

higher than the operating temperatures of LTS materials. The process of cooling LTS materials to their critical temperature is expensive and often difficult, which limits the commercial applications of LTS technology. Conversely, the lower cost of cooling HTS materials broadens the range of potential commercial superconductor applications.

A combination of three conditions must be met for a material to exhibit superconductor behavior:

- The material must be cooled below its critical temperature (T_c);
- The current passing through a cross-section of the material must be below a level known as the critical current density (J_c); and
- The magnetic field to which the material is exposed must be below a value known as the critical magnetic field (H_c).

Superconductor materials were initially discovered in 1911. Before 1986, no known superconductor had a critical temperature above 23 Kelvin. Zero Kelvin is the absolute zero of temperature and is the equivalent of minus 459 degrees Fahrenheit; 23 Kelvin is the equivalent of minus 418 degrees Fahrenheit.

In 1986, a breakthrough in superconductivity occurred when two scientists, Dr. K. Alex Müller and Dr. J. Georg Bednorz, at an IBM laboratory in Zurich, Switzerland, identified a ceramic oxide compound, an HTS material, which was shown to be superconductive at 36 degrees Kelvin (minus 395 degrees Fahrenheit). This discovery earned them the Nobel Prize for Physics in 1987, which is one of four Nobel Prizes awarded to date for work on superconductivity. A series of related ceramic oxide compounds that have higher critical temperatures have been subsequently discovered. This family of ceramic superconductors has come to be known as HTS materials. Some of these materials are being actively used throughout the world and by us for practical wire applications. A variety of organic materials have also been discovered, in a class called “fullerenes,” with critical temperatures ranging between those for high temperature ceramic oxide superconductors and low temperature metallic superconductors. Because of the expense and complexity of synthesizing the fullerenes and also their limited performance in a magnetic field, these have generally not been actively considered for wire applications.

In early 2001, it was discovered that a well-known and widely available material, magnesium diboride (MgB_2), has a superconductor transition temperature at 40 Kelvin (minus 387 degrees Fahrenheit). The properties of MgB_2 are consistent with those of LTS materials. Because of its potential low cost and ease of synthesis, work has been initiated around the world to investigate the use of MgB_2 in wire applications. We initiated a program to investigate the commercial viability of MgB_2 . Our conclusion is that it will be very difficult for MgB_2 wire to compete against HTS or LTS-based wires. We have stopped development activities on MgB_2 but continue to monitor new developments and are poised to reestablish our program if the need arises.

Power Electronics Technology

Advances in power electronics technology are enabling new, more reliable and efficient use of electric devices and are providing a critical component fundamental to new integrated power solutions that improve the reliability and quality of power delivered to users. Today, our growing digital-based economy demands better power reliability and quality for higher performance through faster power conversion devices and active grid management. Power conversion and active grid management are enabled by power electronic devices, which convert generated or transmitted electric power to the appropriate form for a particular electrical application. Common examples of power electronic conversion include: AC-DC converters used at the interface between AC power sources and a number of applications that use only DC power; DC-DC converters used to change the DC voltage of a source; and DC-AC converters, usually called inverters, used to convert DC power to AC power. DC, or direct current, is typically produced by batteries and fuel cells, while AC, or alternating current, is typically produced by electric generators and used in homes and businesses.

[Table of Contents](#)

Power electronic converters incorporate power semiconductor devices that switch, control and move large amounts of power faster and with far less disruption than the electromechanical switches that have historically been used. These power converters can be used in a variety of applications from motor drives, power supplies, voltage regulators, and wind turbines to fuel cells, microturbines and photovoltaics.

Ongoing advances in power electronics technology have spawned new, more reliable and efficient power semiconductor switching devices. AMSC employs devices such as insulated gate bipolar transistors (IGBT) operating in the 300 to 6,000 volt range and at switching frequencies up to 24,000 hertz. We incorporate these into AMSC's proprietary, state-of-the-art power electronic converters, which together enable lower cost and more effective, integrated solutions for power reliability and quality. Rather than using discrete packaging, AMSC integrates the IGBTs onto printed circuit boards made of isolative and conductive materials, which increases reliability and reduces manufacturing cost. These circuit boards form a critical building block in our more powerful and smaller power electronic converters. Other key attributes of AMSC's power converters are their inherent programmability, flexibility and scalability. Embedded controllers allow end users to customize power converters to meet precise application requirements and optimize the performance characteristics of the device.

Market Overview

Power Demand and Transmission Capacity

The Electric Power Research Institute (EPRI) has estimated that electricity as a percentage of total energy use in the U.S. was 25 percent in 1970, has recently reached 40 percent, and will increase to 50 percent by 2020. This large projected increase is being driven in part by growth in the use of computers, the Internet, telecommunications, and other consumer-based electronic products. Projected growth rates for electric power consumption by these newer technologies are far higher than for traditional uses of power, which have historically grown in proportion to the GDP. We believe this growth in power consumption, and the corresponding demand for more reliable and higher quality power to support digital applications, will create demand for many of our products.

We believe another key factor affecting the market for our products and technologies is the expected need to upgrade the U.S. transmission infrastructure. In May 2002, the U.S. Department of Energy (DOE) issued a National Transmission Grid Study (NTGS), which highlights the important role the power grid plays in our economy, specifically outlines the major bottlenecks in the nation's transmission system and makes recommendations for eliminating them. The report makes clear that if investment in the grid does not begin now, the electrical transmission grid will become considerably more congested, resulting in lower reliability and higher prices for electricity. We believe that the recommendations outlined in the NTGS report will be favorable to our efforts to commercialize our products and technologies. The report specifically calls for adopting new technologies including superconductors and power electronics to help alleviate transmission grid congestion.

In March 2003, the DOE, in collaboration with the Tennessee Valley Authority (TVA) and the Oak Ridge National Laboratory (ORNL) established the National Transmission Technology Research Center (NTTRC) in Oak Ridge, Tennessee to provide a testing ground for new technologies and products that are designed to meet the needs identified in the NTGS, including those based on HTS materials and power electronics. The DOE, also in March 2003, established a new Office of Electric Transmission and Distribution, which is tasked with carrying out the recommendations of the NTGS. In April 2003, this office sponsored a National Electric System Vision Meeting in which approximately 60 industry, government and university leaders, including a representative from AMSC, gathered to further define the vision for the electric system in the U.S. All of these recent actions by the U.S. government indicate the serious nature of the problems affecting the U.S. transmission grid, the need for significant new investment in the grid, and the need for HTS technology and advanced power electronics as part of the solution. We believe that, going forward, AMSC is well positioned to participate in the anticipated increase in investment in the U.S. transmission grid.

The chart below illustrates the decline in investment in the U.S. transmission grid over the last several decades. This trend is the result of uncertainties with respect to the ownership and the return on investment in transmission grid assets caused by uncertainties in potential changes in transmission grid regulations and policies. We believe this decrease in investment in the transmission grid in the U.S., coupled with the increasing demand for more electric power, has contributed to pent-up demand for transmission grid solutions.

U.S. Transmission & Distribution Investments

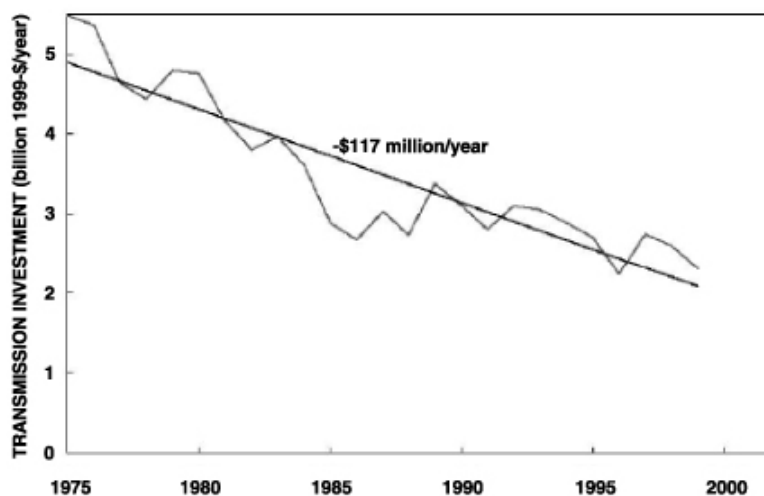

Fig. 3. Annual transmission investments from 1975 through 1999.

We expect that pent-up demand for transmission grid solutions will be favorable to sales of our current and planned products. In addition, we expect demand for our products and technologies to increase with changes now taking place in certain regulations and policies related to transmission grid operation and expansion of the transmission grid. We believe that the latter changes could stimulate investment in the grid just as deregulation of the telecommunications industry created rapid investment in optical fibers in the 1980s and in power generation equipment in the late 1990s.

Power Reliability and Power Quality

The reliability of the power transmission network and the quality of power delivered to customers are becoming increasingly important in today's economy.

Grid congestion caused by growing electrical demands on capacity-constrained power lines and cables, in addition to voltage instability and low voltage in the power grid, are causing significant reliability problems for the nation's growing digital-based economy.

Downtime due to power-related problems is becoming an increasing concern to many industries as the equipment used to manufacture products utilizes more and more power-sensitive digital components. Protection against power quality problems, such as voltage sags lasting two seconds or less, can provide significant

[Table of Contents](#)

economic value to large industrial users of power. Such momentary sags cause more than 90 percent of all plant shutdowns, which can last from hours to days and be very costly. In 1998, Sandia National Laboratories estimated that the annual cost to U.S. businesses of power disturbances is \$150 billion with \$114 billion or 76 percent resulting from voltage sags and other voltage regulation problems. EPRI estimates that the cost of power disruptions to the U.S. economy is at least \$120 billion per year, and growing by as much as 10 percent annually.

Power Reliability: “Power reliability” refers to the ability to deliver power where and when it is needed. Operators of transmission and distribution grids quantify reliability as the fraction of time the grid is up and running, after subtracting time needed for planned maintenance. Grid operators are increasingly confronting reliability issues arising from the capacity limitations of transmission and distribution lines (overhead) and cables (underground). Because lines and cables are made with either copper or aluminum wires, they heat up due to the electrical resistance of these metals. Pushing too much power through a line or cable will heat it up to its “thermal limit.” At that point, more power flow through the line or cable will cause it to fail. Thus, as demand for power increases in the digital age, it is necessary to upgrade existing transmission and distribution corridors with more or higher capacity lines or cables.

Today, most transmission and distribution lines and cables are run at only 40 to 60 percent of their thermal limits. This is because individual lines and cables reach their “voltage stability limit” well below their thermal limit. Driving more power through a grid when some of its lines and cables are operating above their voltage stability limit at peak demand times causes either low voltage in the grid (a “brownout”) or risk of sudden, uncontrollable voltage collapse (a “blackout”). The solution to power reliability problems lies in augmenting transmission and distribution grid capacity.

The traditional way to increase power grid capacity and voltage stability is to install more overhead power lines. This allows for redundancy of power flow pathways and allows grid operators to safely run systems close to the thermal limits of the weakest links in the grid. However, as a result of declining investment in the power grids in the U.S. during the last several decades, as well as rising public resistance to new overhead lines due to environmental, aesthetic and health concerns (which can result in permitting processes of five to 10 years or more), few new power lines are being built.

At the local distribution level, the theoretical solution to increasing electricity delivery capacity is to increase the number of copper or aluminum distribution lines and underground cables. However, this approach is not generally practical in large metropolitan areas for these two important reasons: (i) many existing underground conduits carrying power distribution cables are already filled to their physical capacity and cannot accommodate any additional cables; and (ii) adding new conduits requires securing new or expanded rights of way and digging up streets to lay new conduit pipe, tasks that are extremely costly and impose significant disruptions.

We offer several immediate and future innovative solutions to these challenges. We sell integrated power electronic systems commercially today. Currently, we have 18 integrated power electronic systems at nine customer locations in the U.S. and Canada that provide voltage stabilization in transmission and distribution power grids. These transmission reliability systems enable grids to operate closer to their thermal limits, which in many cases means the existing grid can carry more power. Our HTS wire is expected to enable a new class of high capacity, environmentally benign and easy to install transmission and distribution cables that address transmission grid capacity issues by increasing the thermal limit of existing or new rights of way. We expect that our wire will be utilized in a number of new HTS power cable demonstrations over the next two years. Our HTS dynamic synchronous condensers—AC rotating machines that generate or absorb real or reactive power to support and stabilize grid voltage—are designed to increase power flow through existing transmission lines. In November 2003, we plan to install the first prototype in a transmission grid.

Power Quality: Distinct from the issue of power reliability is the problem of power quality. Power quality anomalies (most commonly voltage “sags,” which are momentary drops in the voltage in power grids) are an expected part of normal grid operations, such as reclosure operations used to clear electrical faults in grids.

[Table of Contents](#)

The electrical faults may be caused by a variety of factors, including lightning strikes, animals or tree limbs in contact with power lines and even what the industry refers to as “car / pole interactions.” To a residential customer, a momentary power sag may be manifest as nothing more than a briefly flickering kitchen light. To a continuous process manufacturer, that same power quality problem may cause a costly interruption in microprocessor-controlled manufacturing lines. Because momentary sags are part of the normal operation of the grid, they must be solved at the customer’s site, which we achieve with our power electronics-based industrial power quality solutions.

We believe we are well positioned to participate in the expected increases in investment in grid reliability solutions and in industrial power quality solutions over the next decade and beyond. We anticipate that our participation in this growing opportunity will be through sales of our existing power electronics-based solutions and in the future, through sales of our HTS dynamic synchronous condensers and our HTS wires for high-capacity power cables. Future applications could also include fault current limiters and transformers.

Power Electronic Converters

Driven in part by the trend toward a global digital economy, the complexity of switching power into useful forms is increasing. This, in conjunction with increasingly economical and efficient power converters, is driving the market for power conversion applications. Industry experts estimate that more than 20 percent of all power generated in the U.S. passes through power electronic converters at power levels exceeding 60 kilowatts (kW) and that this amount will increase with the introduction of new applications, including distributed and dispersed generation of power.

Electrical devices are becoming more “intelligent” as microprocessors and embedded controllers add new functionality to power converters. Key trends in power electronic converters designed for use in power infrastructure applications include greater modularity and standardization, programmability, and the demand for smaller units with higher power density, which is the amount of power handled per unit volume of the converter device. We are focusing our power converter product development activities on power levels of 60 to 1,000 kW because we believe this is the market segment in which our power conversion technology offers the greatest value to customers.

Based on our market analyses, we believe that the addressable market for our power converter product line, at power levels greater than 60 kW, is approximately \$1 billion per year. The addressable markets include motor drives, uninterruptible power supplies and other power quality systems, wind turbines, electric vehicles, transmission grid reliability solutions and distributed and dispersed generation devices, such as fuel cells and diesel generators.

Rotating Machines: Motors, Generators and Synchronous Condensers

We have developed large-scale, HTS rotating AC synchronous machines that have, to date, been demonstrated as motors. This same AC synchronous rotating machine platform can be used as a generator or as a dynamic synchronous condenser. We plan to develop and commercialize HTS motors, generators and synchronous condensers.

The market for large electric motors and generators is well developed, with strong competitors and intense price pressure. We estimate that the annual worldwide market for industrial motors (machines with ratings of 1,000 horsepower [hp] or higher) is approximately \$1 billion, and is expanding at a compound annual growth rate (CAGR) of 2 to 4 percent. The worldwide market for utility-scale electrical generators (with power ratings over 100 mega-volt-amperes [MVA]) is approximately \$1.6 billion per year, and the market for industrial generators (typically 20 to 100 MVA) is approximately \$0.4 billion. The worldwide market for utility and industrial generators is growing at a CAGR of approximately 2 to 4 percent.

During the last 10 years, the commercial cruise ship industry has made a transition to electric propulsion systems in which electric motors are used to directly drive the ship’s propeller. An electric generator powered by a gas turbine, or other prime mover, provides the electricity to run the motor. The first ship type to convert to an electric propulsion system was the cruise ship, with the conversion from steam to electric propulsion of the Queen Elizabeth 2 in 1987. Today, virtually all commercial cruise ships are being built with electric propulsion systems. Similarly, many other types of commercial vessel, including product tankers, Ro-Ro (Roll-on Roll-off) and Ro-Pax (Roll-on Roll-off Passenger), liquified natural gas carriers, cable layers, research ships and supply craft have been redesigned to incorporate the benefits electric propulsion systems provide over the older mechanical propulsion. The benefits HTS motors and generators provide to the marine propulsion market include smaller size, lighter weight, greater efficiency, and lower noise. These benefits translate into reduced fuel costs, better reaction time and increased cargo and passenger cabin space.

Naval ships around the world are converting to electric propulsion as well. In January 2000, the U.S. Navy declared it would transition to electric propulsion systems and in 2002 awarded a contract for the design of an advanced, electrically-propelled new generation of destroyer – the DD(X).

The current market for electric motors and generators for ship propulsion systems is approximately \$450 million. Industry experts forecast that this market will grow at a CAGR of up to 20 percent over the next 10 years due to the accelerating transition to electric drives, which is already well underway today. The following chart shows anticipated growth rates in addressable markets for HTS rotating machines.

World Addressable Markets: HTS Rotating Machines

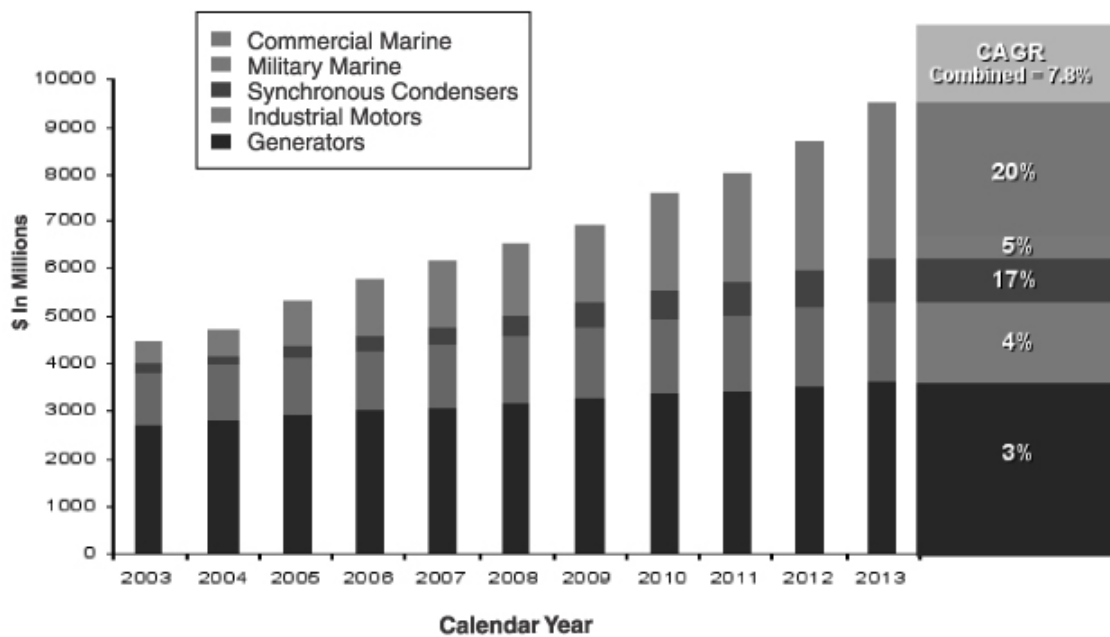

Sources: MSCL; Arthur D. Little, McCoy, TVA, ANB

HTS rotating machines, when operated as dynamic synchronous condensers (DSC) in power grid substations, are capable of generating or absorbing reactive power, which is measured in VARs (volt-amp)

[Table of Contents](#)

reactive). In addition to continuous VAR support, an HTS DSC or SuperVAR™ machine can help stabilize power grids by providing a fast, reliable, low-cost response to transient and disruptive events. This is accomplished through the HTS machine's unique ability to provide an estimated 6-8 times its rated capacity (overload) in response to transient events. SuperVAR machines also produce VARs on a continuous basis to 100 percent of their full rating (both leading and lagging) to increase grid transmission capacity.

Based on our own market analyses and those of TVA, the largest public utility in the U.S., we expect the need for VARs in support of both steady-state and transient grid operation to continue to rise as the demand for power increases. It is currently estimated that approximately 10,000 mega-VAR (MVAR) of additional support are needed today in the U.S. market, with an anticipated growth rate of 4 percent per year. The international market is expected to grow at more than double this rate. We believe HTS DSCs can supply a major fraction of this demand.

Large electric rotating machine production is labor intensive, requires a large fixed asset investment, and does not lend itself to mass production techniques. As a result, many manufacturers of large motors and generators are seeking opportunities to reduce manufacturing and investment costs to improve profitability. We believe size and weight reductions in large electric motors, generators, and SuperVARs resulting from the use of HTS technology will enable significant reductions in manufacturing costs. During the last two years, we have shifted our focus in the development of electric rotating machines to ship propulsion and DSC applications. We believe we are well positioned to be a leader in these rapidly growing markets.

Our Businesses

We are organized into three business units: AMSC Wires, SuperMachines and Power Electronic Systems.

Each business unit is run separately by a vice president and general manager, who reports to the chief executive officer. Although these business units are run independently, we leverage common customer and technology opportunities across all of the business units. Each of our business units is engaged in the manufacture and sale of commercial or prototype products and in the development of technology and new products. Our Power Electronic Systems business unit has been selling commercial products since 1999. Our AMSC Wires business unit is selling commercial HTS wires that it produces at a full-scale commercial manufacturing plant we opened in December 2002. Our SuperMachines business unit is developing, assembling, and testing prototype motors and synchronous condensers.

A customer set common to all of these business units is transmission grid operators, and thus, much of our sales and marketing efforts are directed to this customer category. A significant part of our sales and marketing efforts is focused on the U.S., however, we are currently marketing our products and technologies around the world. Our channels to market include direct sales, agents and manufacturers' representatives.

To facilitate our traditional sales and marketing efforts, we have created the Advanced Grid Solutions business development team, comprised of seasoned veterans who have worked in all aspects of power generation, transmission, government regulation and policies, cryogenic systems and cable technology. Also participating in the business development team are four transmission planners with well over 70 years of transmission planning experience and a broad depth of knowledge of the design and structure of transmission and distribution grids. These transmission planning experts use sophisticated software programs to perform power flow and stability analyses on power grids to help determine the best solutions to increase reliability and capacity. The Advanced Grid Solutions business development team is currently working with electric utilities and industrial users of power to create solutions that utilize our current or planned products.

AMSC Wires Business

The AMSC Wires business unit is responsible for the design, development and manufacture of HTS wires. It sells wire to original equipment manufacturers (OEMs) that incorporate HTS wire into value-added products.

[Table of Contents](#)

Our commercial wire product is a multi-filamentary composite wire, typically called “first generation” or “1G” wire, which can carry more than 140 times the power of copper wires of the same dimensions. Currently, the AMSC Wires business unit is selling 1G wire primarily to OEM manufacturers that incorporate the wire into prototype power cables, motors, generators and magnet applications for sale to the utility, transportation, ship building and industrial processing markets. Our SuperMachines business unit is an AMSC Wires customer. We also sell wire to customers that are in early stages of research and development. These customers use the wire in products such as power transformers, fault current limiters and electromagnet applications in the medical industry and other fields.

AMSC Wire Production Techniques: We produce our commercial wire multifilamentary composite HTS wire with deformation processing, which is analogous to the techniques used in the existing metal wire industry. In this approach, a silver alloy tube is packed with an oxide precursor powder and sealed. The tube is then deformed into a wire shape by a variety of deformation processing techniques such as wire-drawing and rolling. Finally, the wire is heat-treated to transform the precursor powder inside the wire into a high temperature superconductor. The resulting composite structure consists of many fine superconductor filaments embedded in a silver matrix. The filaments of HTS material, which are typically one-sixth the thickness of a human hair, extend through the entire length of the wire. The composite structure is the subject of a patent owned by the Massachusetts Institute of Technology (MIT), based on an invention by Dr. Gregory Yurek, AMSC Chairman of the Board, President, Chief Executive Officer, co-founder, and a former professor at MIT, and co-founder Dr. John Vander Sande, a professor at MIT, and a member of the Board of Directors. This patent is licensed to AMSC on an exclusive basis until its expiration date in 2010.

We have received additional patents based on the 1G wire structure and processes related thereto. As of March 31, 2003, we have approximately 162 patents and patents pending worldwide related to 1G wire technology. As of March 31, 2003, we also have licenses to approximately 59 worldwide patents and patents pending owned by others for 1G technology. We believe we have a very strong intellectual property position in the area of 1G wire.

Over the past year we have made significant progress in expanding our 1G wire manufacturing capacity to meet growing customer demand for HTS wire. In December 2002, we produced our first saleable wire in a new 355,000-square-foot HTS wire manufacturing facility located in Devens, Massachusetts. Operations and engineering for the AMSC Wires business unit has relocated to this facility and production for customer orders is now completed there as well. Current production capacity is 900 km/year. The facility has been designed to expand the production capacity on a “just-in-time” basis as product demand increases. Costs for the first expansion to 1,500 km/year will be about \$350,000, which will be implemented in line with customer demand.

We believe that the Devens manufacturing facility will provide us with a competitive advantage as the market for HTS wire continues to grow over the next several years. The facility, at full capacity, is capable of producing 20,000 kilometers (12,000 miles) of 1G HTS wire annually. We estimate that the additional cost to expand from our current capacity to 20,000 kilometers per year will be approximately \$30 million. However, we do not anticipate expanding to full capacity for 1G wire because we now believe we will transition our wire manufacturing operation in our Devens facility over the next three to four years to an inherently lower cost wire manufacturing methodology, as discussed later in this section.

We have been successful in developing and producing HTS wire with performance levels sufficient to meet the technical needs for applications such as power cables, utility generators, shipboard motors and several electromagnet applications. While we believe our HTS wire will meet the commercial needs for these applications, there can be no assurance that we will achieve this goal or, if we do achieve it, that the market will adopt these new products.

[Table of Contents](#)

In the past few years, we have made significant progress in improving the price-performance ratio of our HTS wire. We believe that AMSC wire is the standard for the industry based on both the price and the performance of our wire. The price-performance ratio is obtained by dividing the price-per-meter (\$/m) we charge customers by the amount of kilo Amperes (kA) this wire can carry.

The key factor in driving down the price-performance ratio of our 1G wire in the next few years is our ability to leverage our HTS wire manufacturing plant and lower product costs through the economics of volume manufacturing, design improvements, factory automation and enhanced productivity. We have anticipated that manufacturing process improvements, developed in our 1G pilot operations and incorporated in our commercial plant, would also create improvements in the electrical performance of our wire. In fact, wire produced in our new operation has higher performance characteristics than wire produced in our pilot operation. Its average performance (measured in Amperes) is also more than 50 percent higher than that of the wire manufactured by our closest competitors.

Continuous improvements in the electrical performance of our 1G HTS wires is an important factor in reducing the price-performance ratio of our wire and in meeting customer specifications for high electrical performance. However, we must also continue to improve procedures in each of our 1G wire manufacturing steps in order to increase our manufacturing yield. We estimate that manufacturing yield for 1G wire from our new plant during its first year of operation will be in the range of 40 to 60 percent. We expect to achieve yields at this level during fiscal 2004 and to continue increasing yield as we refine our standard operating procedures and optimize performance of the new equipment and machinery.

The current selling price of 1G wire varies according to customer specifications. For many customers, the price is typically \$20 per meter. The corresponding price-performance ratio is \$160/kAm using 125 Amperes (0.125 kA) as the typical performance of our commercial wire today. This represents a 20 percent reduction in our price-performance ratio over the past year.

We believe we can drive down the price-performance ratio of our 1G wire to \$50/kAm through further manufacturing cost reductions and additional improvements in electrical performance. A price-performance ratio of \$50/kAm is more than sufficient to meet the commercial and technical requirements of ship propulsion motors and generators, utility generators, power cables in metropolitan-area applications and other superconductor electromagnet applications.

Our strategy for future wire cost reductions has changed over the last year due to significant success in the development of our coated conductor composite HTS wire, also called "second generation" or "2G" wire. Our 2G wire has a different architecture from that of our 1G wire, as shown in the figure below. Our 2G wire promises to duplicate or exceed the performance characteristics of our existing wire at a two to five times lower price-performance ratio. Importantly, this 2G wire will be a form, fit, and function replacement for our 1G wire, assuring that current and potential AMSC wire customers can benefit from continued cost reductions without the need to re-tool their production equipment from 1G designs. We believe that we will ultimately provide our 2G wire at a price-performance ratio superior to that of copper wire, which typically has a price-performance ratio of \$15/kAm to \$25/kAm. However, because of the time required to scale-up and establish 2G manufacturing, we expect that our primary HTS wire product over the next three to four years will remain 1G multi-filamentary composite wire. Our plan is to raise additional capital in order to build a pilot plant for 2G wire in our Devens, Massachusetts facility, as originally planned. This will take about two years to accomplish. After successful implementation of the pilot plant, we expect to expand the pilot operation into a full manufacturing operation at a rate of expansion dictated by customer demand. We estimate that the 2G wire manufacturing capacity at the Devens facility at about 65,000 km per year, based on our current 2G manufacturing methodology, and assuming the entire facility is converted to 2G manufacturing.

HTS Wire Architectures

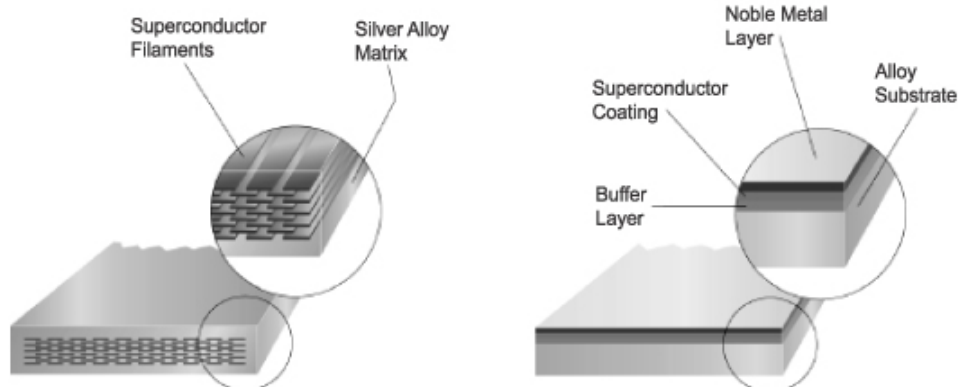

Multi-Filamentary Composite
(AMSC commercial, in production)

Coated Conductor Composite
(AMSC second generation, under development)

AMSC has invested seven years and more than \$48 million in the development of a 2G HTS wire manufacturing methodology that we believe will allow us to achieve a price-performance ratio equal to or lower than that of copper. We believe we have accomplished the initial portion of our 2G development goals. Although some of the technical goals we have achieved have also been met by other companies, we believe that our manufacturing process has significant economic advantages.

Key Markets for HTS Wires (Power Cables): We believe that an important application for our HTS wire is high-capacity power cables. Because of the high power capacity of HTS wire, HTS power cables have the potential to carry up to 10 times more power, depending on the design and operating characteristics of the cable, than copper-wire cables of the same dimensions. The performance levels and mechanical properties of our HTS wire are sufficient today to meet the technical requirements for cables that can alleviate congestion in power transmission systems.

There are several designs for HTS power cables that are being developed and tested by a number of cable manufacturers around the world. In all cases, the cryogenic coolant for the HTS wires in these cables is liquid nitrogen. Nitrogen, which comprises approximately 79 percent of the air we breathe, is an environmentally friendly, nonflammable material. When cooled by standard industrial refrigeration techniques, nitrogen gas turns into a relatively inexpensive liquid, which is used in many applications, from steel making to crushing of spices to cryogenic freezing of biological materials on farms.

HTS power cables must be thermally insulated from their surroundings to minimize the refrigeration expense associated with keeping the nitrogen in its liquid state, which, in turn, keeps the temperature of the HTS wire in the cable below its critical temperature. The cryogenic insulation, typically called a cryostat, is made in a variety of forms depending on the cable architecture. Cryostats of the type needed for HTS power cables have been manufactured for decades by companies such as Nexans and Vacuum Barrier Corporation. The kind of cryogenic refrigeration equipment needed for HTS power cables is typically made by companies such as Air

[Table of Contents](#)

Liquide, Air Products and Chemicals, Praxair and others. Further developments to improve the costs of both cryogenic refrigeration and cryostats are necessary to catalyze broad market adoption of HTS cables.

HTS cables can provide a variety of advantages over conventional copper cables. Most important are the power density and very low impedance (VLI) characteristics of several cable designs. These product features provide end user benefits in the following areas:

Infrastructure Siting and Permitting: Due largely to environmental and property value concerns, acquiring permits for overhead transmission lines has become a very difficult process that can take over a decade with no guarantee of success. Conventional underground copper transmission cables can be applied in some applications, but technical considerations limit widespread use. Co-axial HTS underground cables alleviate these concerns. With such HTS cables, fewer cables are needed to transmit the same amount of power, they have very low impedance, soil heating concerns are eliminated, and no stray electromagnetic fields (EMF) are produced.

Relieving Network Congestion: Co-axial HTS cables have VLI characteristics. Since electricity flows along the path of least impedance, these HTS cables can be used to change the flow dynamics of a transmission network. When properly placed, HTS cables can be used to draw power flow away from overtaxed conventional cables or overhead lines and expand the overall system capacity with minimal new infrastructure or disruption. As part of our marketing effort, we have developed a business development group called Advanced Grid Solutions, which has the transmission planning expertise to model individual utility systems and work with utility planning groups to determine how HTS cables can add value in their networks.

Controlling Power Flow: VLI HTS cables have another significant benefit. Because they have very low impedance, AC power flow through them can be controlled with conventional series reactors or phase shifters. This is becoming more important as the electrical industry becomes more deregulated and as interest in merchant cable systems become more widespread. Historically, power flow has been controlled by converting AC power to DC power. This requires the use of inverters and rectifiers that are much more expensive than series reactors and phase shifters. Even if DC power is chosen, HTS cables may be the best choice. DC HTS circuits double the ampacity of similar sized AC HTS circuits and can provide up to 10 times the amperage of similar-sized conventional DC cables. In larger DC power applications the economics of HTS cables are superior to conventional DC circuits.

Reduced Construction Costs: For many years, urban retrofit projects have been recognized as an ideal application for HTS cables. In many urban areas the demand for power has outgrown the existing infrastructure. To solve this problem with conventional technology incurs the major disruption and large expense associated with digging up streets to install new conduit systems. Because HTS cables transmit significantly more power than conventional cables, in many cases it is possible to replace existing cables in existing conduits with HTS cables, and more than triple the available power without trenching or other disruptive construction activities. Even when some trenching is needed with HTS cables, the disruption and expense is much less since fewer cables are needed and multiple cables can be put in one trench without causing thermal concerns.

Voltage Reduction: The high amperage characteristics of HTS cables allow significant reductions in voltage without a reduction in total power transferred. This can result in significant savings in support infrastructure such as substations, terminations, splices, etc. In addition, the ability to transmit large amounts of power at lower voltages can often eliminate the need for locating substations in sensitive or expensive sites.

Lower Power Losses: HTS wire transmits DC power with zero resistive losses. This feature makes DC HTS circuits nearly perfect conductors. On a net loss basis (including energy consumed for refrigeration) DC HTS circuits and most AC HTS circuits consume less energy than conventional circuits.

In order for electric utilities and transmission grid operators to adopt HTS cables, they must first see the successful testing and operation of HTS cables in high voltage test facilities and in actual grid installations. The

[Table of Contents](#)

first phase of HTS cable demonstrations began in 1996 and ended in the first half of 2003. The demonstration projects involved in the first phase were highly successful; only the Detroit Edison HTS cable project, which was run by Pirelli Energia e Sistemi (Pirelli), fell short of its goal when leaks developed in the cable's thermal insulation system (the cable cryostat). The list of projects in the first phase includes:

- Pirelli: 50m, 115kV, 2000 A, Pirelli test facility (1996-1999)
- Pirelli : 120m, 24 kV, 2400 A, Detroit substation; (2001-2002)
- Sumitomo : 30m, 66 kV, 1000 A, TEPCO test facility; (1996-1999)
- Sumitomo: 100m, 66 kV, 1000 A, TEPCO test facility; (2001-2002)
- Southwire: 30m, 12.5 kV, 2600 A, Southwire manufacturing plant; (2000-2003)
- NKT Cables: 30m, 30 kV, 2000A, Copenhagen substation; (2001-2003)
- Condumex: 5m, 2000 A, Condumex test facility; (2001-2002)

Eight to 10 new HTS cable demonstrations are expected to be underway between now and 2005. These demonstrations will occur in the US, Europe, China, Korea, Japan and Mexico. In April 2003, AMSC was selected by the DOE as prime contractor to install a 600 MW, 138 kilo-Volt (kV) HTS cable system in the transmission grid of the Long Island Power Authority (LIPA) on Long Island, New York. We selected Nexans as our subcontractor to manufacture the HTS cable, the cable cryostat and the cable terminations, and we selected Air Liquide to provide the cryogenic system design and the refrigeration equipment. The DOE will provide project financing and technical review. AMSC Wires will supply about 128 km of HTS wire to Nexans for this project. The cable system is being designed to become a permanent part of the LIPA grid. This project is viewed by LIPA as the first phase of an HTS circuit that will provide power to much of Long Island. We view this project as a final precursor to commercial HTS cable sales. We are currently discussing commercial power cable applications with several potential end users in the U.S. and abroad. There can be, however, no assurance that operators of transmission and distribution grids will adopt HTS power cables after the demonstration phase is complete. To the extent that HTS cables are adopted for commercial applications, we believe our HTS wire will be competitive and that we will have a significant market for our HTS wires in power cable applications.

Key Markets for HTS Wire (Utility Generators): We believe another significant market for our HTS wire will be utility generators that produce 100 MVA or more of power. Benefits of using HTS wires in these generators include improved VAR control, longevity (HTS generator coils run "cold," so there are no thermal stresses), smaller size, weight and footprint, improved energy efficiency, and potentially lower costs. General Electric Power Systems (GEPS), a business of the General Electric Company, is currently developing a 100 MVA HTS electrical generator using AMSC wire. We have been selected by GEPS as their primary wire supplier for utility generators. Over the last three years, we have supplied HTS wire to GEPS for test purposes.

The first HTS rotor for a 100 MVA generator is being developed by GEPS and is expected to undergo testing in 2004. We believe commercial HTS utility generators could be operational by 2005. According to estimates by GEPS, the performance and projected costs of our 1G wire are sufficient to meet the technical and economic objectives of commercial HTS generators.

The four primary manufacturers of utility generators are GEPS, Alstom Power Conversion, Siemens-Westingshouse and Mitsubishi Electric Corporation. We are currently marketing our HTS wire to all of these generator manufacturers with the goal of becoming the primary wire supplier to each of them; however, we can make no assurances that these generator manufacturers will develop commercial HTS generators and, to the extent they are successful, that they will choose our HTS wire.

Key Markets for HTS Wire (Rotating Machines): Our SuperMachines business unit produces rotating HTS machines and is a customer for wire produced by the AMSC Wires business unit. AMSC Wires also sells its HTS

[Table of Contents](#)

wire to other manufacturers of rotating machines. SuperMachines is focused on electric motors and generators for marine propulsion and on synchronous condensers for transmission grid reliability. A review of the SuperMachines business unit's products and markets is provided later.

We believe the market for HTS wire for electric motors and generators will be large and we believe we are in a position to capture a significant share of this market; however, we cannot provide assurance that a market for HTS electric motors, generators and synchronous condensers will develop or, to the extent that it does, that our HTS wire will be purchased by the manufacturers of these machines.

Other HTS Wire Applications: Over the last several years we have sold our HTS wires to a number of OEMs and research and development organizations that are developing other applications for HTS wire. In March 2003 we received an order from Dupont for an HTS electromagnet for a commercial-scale industrial magnetic separator, which will use about 40 km of our HTS wire. This is a follow-on order to the electromagnet we delivered two years ago to Dupont for a prototype magnetic separator. That prototype exceeded Dupont's design goals in testing. Dupont expects to produce commercial magnetic separators after the successful operation of the electromagnet we are currently producing.

We have also sold HTS wire for transportation, military, medical and other applications. Some of these applications have significant near-term sales potential, while other applications, such as transformers and fault current limiters, are in the early development stage.

Some of these other applications have the potential to become important markets for our HTS wire, and we will continue to market our wire to the developers of these and other new products. We cannot make any assurances, however, that these markets will develop, that they will become significant markets or that our wire will be purchased for use in these markets.

Sales and Marketing for HTS Wire: We plan to sell wire to a broad OEM market, and we are aiming for a high market share, which we plan to protect by being the market leader in performance, cost, service and intellectual property. We are focusing our business and market development efforts on key OEM's that we believe are the market leaders. By establishing strong relationships with these market leaders we can foster more rapid market development and have a significant impact on industry standards. Most of our key OEM's are serviced by our direct sales force. However, in some areas we have found it advantageous to form sales alliances to establish ourselves in the market. For example, in the fall of 2001, we signed a multi-year distribution agreement with Kiswire Ltd., a leading Korean wire manufacturer, to distribute HTS wire in the Korean market. As a result of our collaboration with Kiswire, we were chosen to be the supplier of 1G HTS wire for the Korean national superconductor program, which has led to sales and follow-on orders for our HTS wire. We have also made significant inroads into China and expect our first orders from companies in China in fiscal 2004.

Our Advanced Grid Solutions (AGS) business development team, described earlier, is helping us build demand for HTS wire and further penetrate key markets. We are leveraging this team's experience in transmission planning by working with utilities to identify locations in their system where HTS solutions would add value to their power grids. We are also applying the team's project management experience to facilitate project concept development, close orders and implement projects.

Competition for HTS Wires: We face intense competition both from vendors of traditional wires, such as copper, and from competitors who are developing HTS wires. There are several companies around the world that are our competitors in the market for 1G wire. They presently include Sumitomo Electric Industries (Japan), Furukawa Electric (Japan), European Advanced Superconductor, formerly part of Vacuumschmelze GmbH, and as of July 2003, a division of Bruker Biospin (Germany), Innova Superconductor Technology Co. Ltd. (China) and Trithor GmbH (a German start-up company).

[Table of Contents](#)

In October of 2002, we purchased the assets of a 1G wire competitor, Nordic Superconductor Technologies A/S (NST), a subsidiary of Denmark's NKT Holding A/S (NKT), and a direct competitor in 1G wire. The purchase was implemented as a stock transaction with NKT receiving 546,000 shares of our common stock. In return, we received all of the equipment, material, patents and engineering information from NST. NST was shut down and some of the material and equipment has been sold, which resulted in this transaction being essentially cash neutral for AMSC. Other NST equipment has been incorporated into our manufacturing process or will be as we need to increase manufacturing capacity. In addition, the engineering knowledge and customer contacts we received from NST have been valuable in improving our wire products, our manufacturing processes and our further penetration of the market for HTS wires.

We also face competition in 2G coated conductor composite wires from a number of companies in the United States and abroad. These include Intermagnetics General Corporation and MetOx (United States), Sumitomo, Fujikura and Furukawa (Japan), and Theva, Bekaert and a potential spinout from the University of Germany in Germany. Impressive laboratory results have been achieved by some of our 2G competitors. However, we believe that the processes we have adopted will prove to be the best processes to provide not only high performance wire, but also commercial quantities at the lowest cost.

Many of our competitors have substantially greater financial resources, research and development, manufacturing and marketing capabilities than we do. In addition, as HTS markets develop, other large industrial companies may enter these fields and compete with us.

SuperMachines Business

Our SuperMachines business unit is responsible for the design, development, manufacturing, testing and commercialization of HTS electric motors with power ratings up to approximately 50,000 hp (37.5 MW) and generators with power ratings generally in the range of 20 to 100 MVA. This unit buys HTS wire from the AMSC Wires business unit and winds the wire into electromagnetic coils of various sizes and shapes, which are incorporated into the rotors of motors, generators and dynamic synchronous condensers, all of which are AC synchronous rotating machines. In such rotating machines, the rotor coils utilize DC, to which our HTS wire exhibits zero electrical resistance, a feature that typically cuts the electrical losses of AC synchronous rotating machines in half compared with copper wire-based machines.

The use of HTS wire in rotating machines provides us with significant competitive advantages by enabling dramatic reductions in size, weight and manufacturing costs relative to conventional machines. Because of the significant manufacturing cost reductions associated with the reduced size of our HTS rotating machines, we expect the market price of our rotating machines to be equivalent to that of copper-based machines at the same power and torque rating. The advantages of HTS rotating machines in ship propulsion applications are summarized in the following figure:

HTS Ship Propulsion Motors

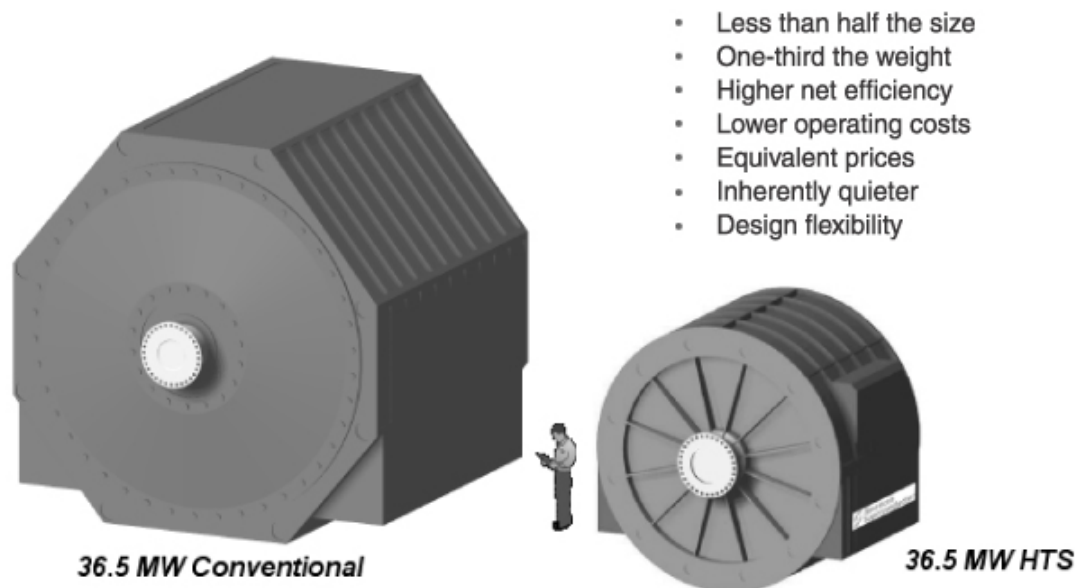

The HTS rotor coils in our superconductor rotating machines are cooled using commercially available mechanical refrigerators located near the machine, which cool the rotor using AMSC-patented techniques. We are also developing new refrigeration system technology that we believe could further reduce the cost of cryogenic cooling.

The cooling systems used for HTS motors and generators are closed loop, meaning that the cooling medium, typically a gas, circulates inside a closed system from the region of the HTS coils on the rotor, where the cooling medium picks up heat, to the cold head of the refrigerator, where the cooling medium releases heat and is chilled again. The cooling media we typically use for our rotating machines are either liquid neon or gaseous helium. In the case of our neon systems, the liquid neon absorbs heat by turning into a gas, which is condensed back to liquid at the cold head outside the rotating machine – much like an R12 cycle in home refrigerators. In the case of gaseous helium, no liquid phase is involved.

Our AC synchronous motors and generators have a higher net efficiency, including the losses associated with the cooling system, than conventional machines of the same power rating. This efficiency gain is particularly noteworthy when an HTS rotating machine is operated at part load, such as in marine propulsion applications when a ship is moving at slow speeds. The stator coils in our AC synchronous machines utilize copper windings, which are cooled either with air, oil or water, in a manner similar to that used for conventional motors and generators.

Our SuperMachines business unit is experienced in HTS rotating machine design, development and testing, and has built a significant portfolio of intellectual property, much of which is protected by 45 U.S. and 64 international patents and patents pending as of March 31, 2003. We believe that we are well positioned to transform a 100-year-old rotating machine industry with our innovative HTS technology. Our history of involvement in the development of HTS rotating machines is shown in the following figure:

AMSC's HTS Motor Development History

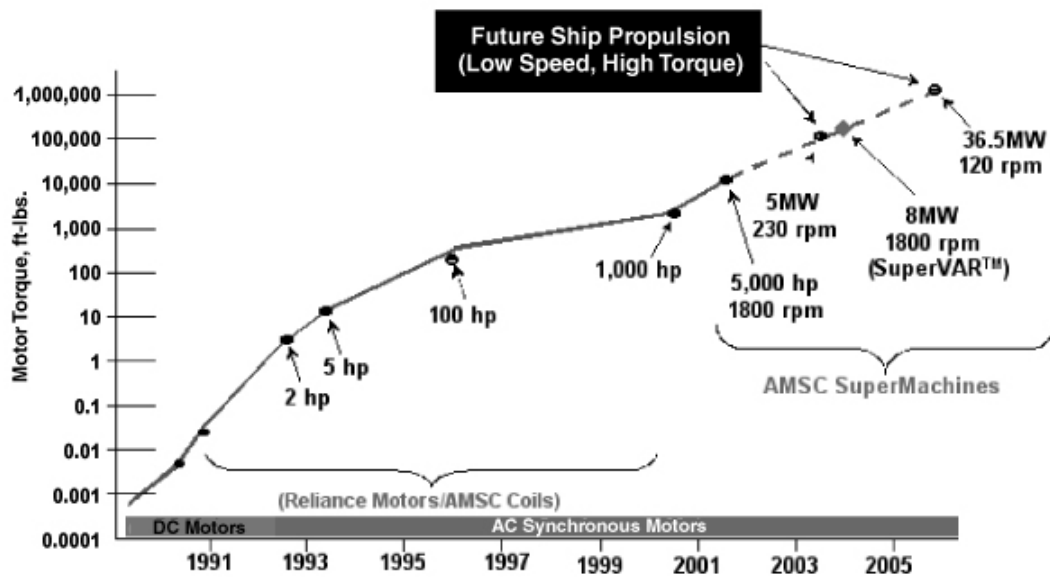

During the past year, we had the opportunity to incorporate our HTS rotating machine technology into a new application. The TVA proposed the use of our AC synchronous rotating machine technology platform as the basis for an HTS dynamic synchronous condenser that would enhance grid stability by generating reactive power at critical locations in its power grid. In January 2003, TVA awarded SuperMachines a contract for the design, fabrication and delivery of a prototype and an order for the first five commercial units of an 8 to 10 MVAR HTS dynamic synchronous condenser, which we have named a SuperVAR™ machine. To demonstrate its operation, the prototype SuperVAR machine will be delivered in November 2003 and installed on the TVA grid in Tennessee. Upon successful completion of prototype testing, SuperMachines will build five commercial units to be delivered to TVA beginning in 2005.

In February 2003, SuperMachines was awarded a contract by the U.S. Office of Naval Research (ONR) to design and manufacture a 36.5MW, 120 rpm HTS marine propulsion motor for delivery in March 2006. This contract, worth approximately \$70 million including certain performance incentive fees, is the largest contract in our history and represents a major milestone in the development of HTS rotating machines in general, and of military and commercial ship propulsion motors, in particular. This contract represents the fifth in a series of U.S. Navy awards to SuperMachines since 1999 for the conceptual and preliminary design of HTS ship propulsion motors and the development of key components for such motors.

In addition to these two important contract awards, SuperMachines completed the design and assembly of a 5MW, 230-rpm HTS marine propulsion motor for ONR on schedule in February 2003. During March, the motor completed a series of standard factory acceptance tests including testing to full torque, full speed and 50 percent

[Table of Contents](#)

load. In addition, noise and vibration signature testing were completed. The motor met all design requirements during these tests and performed well in comparison to predicted values. It is anticipated that the motor will be delivered on schedule to ONR in July 2003.

Our efforts to commercialize HTS rotating machines continue with these new contracts and with the completion of the 5MW marine motor. Our focus in the SuperMachines Business will continue to be marine propulsion motors and synchronous condensers. Future activity may also include HTS generators as opportunities for development and commercial sales arise.

Manufacturing, Sales and Marketing for HTS Rotating Machines: Our SuperMachines business currently operates out of a 27,000-square-foot facility in Westborough, Mass. Operations conducted here include machine design, coil development, manufacturing and testing, exciter development, assembly and testing, and motor assembly and testing. We outsource the manufacture of copper-based stators, which we use in our HTS motors, to conventional motor manufacturers. We also outsource other components that are used in our HTS motors that are not unique to HTS rotating machines. The manufacture of the HTS coils, refrigeration system and exciter are completed internally along with the rotor assembly. During the last year, we outsourced the stator design, assembly and test of the 5MW, 230-rpm ship propulsion motor under contract by ONR to our subcontractor Alstom Power Conversion.

Our plan for future manufacturing, sales and marketing of HTS rotating machines is to form a business alliance with one or more motor manufacturers. We believe this approach will provide us with more effective and quicker paths to manufacture motors and generators, as well as access to established sales and distribution channels and experienced sales teams. We also believe this approach will accelerate market adoption of our new HTS rotating machines. We are currently working with Alstom, Northrop Grumman Marine Systems and Ideal Electric Holding Company (Ideal) as subcontractors for our rotating machine development and demonstration programs. We expect to expand these existing business alliances or to create new ones as we enter the commercial markets for HTS rotating machines over approximately the next two years.

Competition for HTS Rotating Machines: We face competition for our high-power HTS rotating machines from companies that manufacture traditional machines made with copper wires including: GE Industrial Systems, Siemens, Asea Brown Boveri Ltd. (ABB), Alstom, Ideal, Brush Industries, Inc. and Hitachi Ltd.

We also face competition from manufacturers of permanent magnet motors, which have been under development over the last decade. Permanent magnet motors are another technology being considered by the U.S. Navy for electric drives. Companies developing high-power permanent magnet motors include General Dynamics and DRS Technologies Inc. There are also at least two companies, Rockwell Automation and Siemens, that are developing HTS electric motors and who have demonstrated HTS motors over the last several years.

Many of our competitors have substantially greater financial resources, research and development, manufacturing and marketing capabilities than we do. In addition, as HTS rotating machines markets develop, other large industrial companies may enter these fields and compete with us.

Power Electronic Systems Business

Our Power Electronic Systems business unit designs, develops, assembles, tests and sells power electronic converters that rapidly switch, control, and modulate power. This business unit is responsible for product development, marketing and sales of our proprietary PowerModule™ power electronic converter to OEMs, which integrate this product into electric motor drives, distributed and dispersed generation devices, such as micro-turbines, fuel cells and wind turbines, and power quality solutions, such as battery and flywheel-based uninterruptible power supplies. We expect that our PowerModule power converters will encompass power ratings from 60 to 1,000 kW per PowerModule power converter.

[Table of Contents](#)

AMSC PowerModules utilize a proprietary printed circuit board design that enables us to incorporate a microprocessor into the power converter and create programmable power converters. Programmability is important because individual PowerModules or integrated stacks of PowerModules can be programmed to meet the needs of different customers to control and condition varying levels of power from tens of kilowatts to megawatts across a wide range of applications.

Flexibility, scalability and high power density are key PowerModule power converter product features. We believe the PowerModule power converter design will allow us to reduce the manufacturing costs of power electronic converters at power levels above 60 kW.

In addition to PowerModule power converter hardware, our Power Electronic Systems business unit is responsible for software development for the PowerModule power converters, as well as for the software needed to integrate the PowerModule power converters into final systems.

Our primary commercial PowerModule product today has a power rating of 250 kW. This product is known as the PM250™ and it is the power converter we currently use in our commercial distributed superconductor magnetic energy storage (D-SMES), dynamic VAR (D-VAR™) and power quality industrial voltage restorer (PQ-IVR™) product lines.

We have completed the development of our next generation of PowerModule power converters, which we call the PowerModule 1000™, or PM1000™ power converter. The PM1000 power converter family features a scalable, modular and flexible design architecture. It is an intelligent and fully integrated power converter that has a compact package design and yields a very high power density of up to 130 Watts/cubic inch. Features of this design include:

- State-of -the-art IGBT technology;
- Scalable design;
- Flexible architecture; and
- High power density.

We have begun sales and marketing efforts on the PM1000 power converter after successful testing of prototypes supported by a March 2002 development contract from the ONR. As part of its Advanced Electric Power Systems initiative, ONR is developing architectures for Power Electronics Building Blocks (PEBB) for intelligent, reconfigurable systems. We expect to develop low and medium voltage converters based on the PowerModule technology for ship propulsion and other electrical components that will be required for the future all-electric Navy. Power converters are expected to be key components in the integrated power architecture operating, for example, between the shipboard generators and the propulsion motors.

In April 2003, we received our first PM1000 power converter order, from Calnetix, for the supply of the power electronics associated with a 2 MW generator application for the British Royal Navy. With our highly differentiable power electronic converter product, we believe we are well positioned to become a market leader for advanced power electronics for power conversion at 60 kW and higher.

The Power Electronic Systems business unit also develops, markets and sells products that provide customer benefits further up the power electronics value chain by offering a line of power quality and reliability solutions based on our PowerModule power converters, as shown in the following chart.

Power Electronic Systems Value Chain

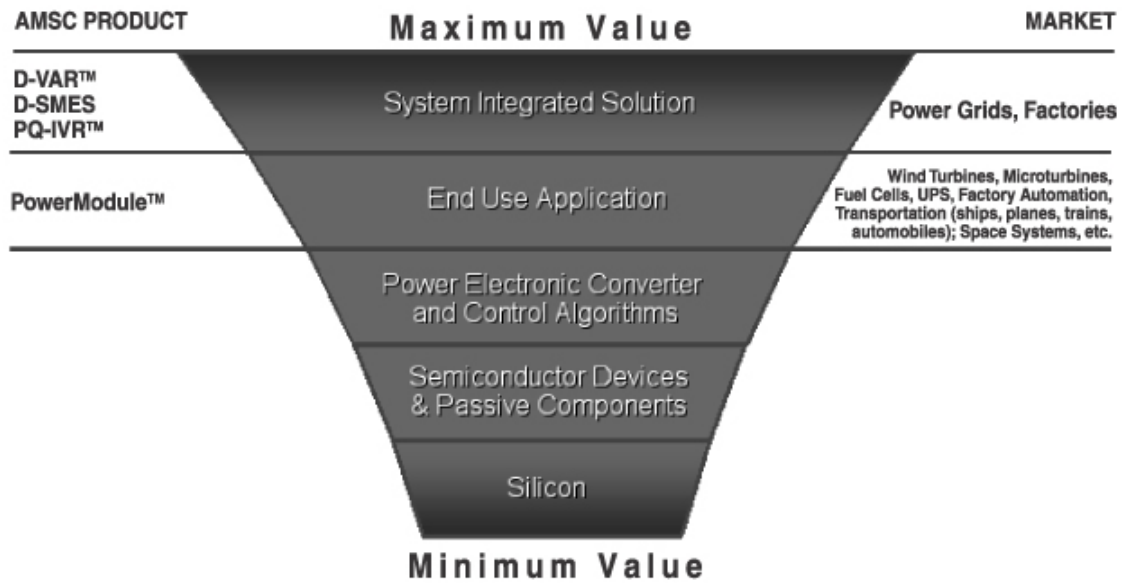

Our power quality and reliability solutions are used in a variety of utility and industrial applications. The systems are based on our PowerModule power converters and may be integrated with a SMES device, which can store and inject large quantities of real power along with the reactive power from the PowerModules. Our commercial integrated power electronic systems include the following:

PQ-IVR™

Our PQ-IVR systems are installed in transmission substations that bring power into industrial manufacturing sites. These systems protect manufacturing operations from the adverse effects of momentary voltage sags. PQ-IVR systems detect voltage drops on the power lines coming into manufacturing sites and instantly inject power into the lines to restore the voltage to the required range of operating voltages. A PQ-IVR may include a SMES device along with the integrated PowerModules if the particular customer site requires the injection of real power in addition to the reactive power generated by the PowerModules. Our transmission planning team works with industrial customers to determine the optimum configuration for each industrial site. Our PQ-IVR systems protect entire manufacturing operations that have electrical loads over 5MW (as opposed to lower power point-of-use protection devices that must be installed at various sites within the manufacturing operation). We believe our PQ-IVR systems provide a cost-effective solution to the problem of voltage sags, which can cost manufacturers millions of dollars in downtime, damaged equipment and lost work-in-process. A major target customer for PQ-IVR systems are semiconductor manufacturers because they are well aware of the impact of voltage sags on productivity and the resulting high cost of downtime.

D-SMES

Distributed SMES (D-SMES) systems protect electric utilities by stabilizing voltage in power grids through the simultaneous injection of large amounts of reactive power from an array of PowerModules and real power from the superconducting magnet. This restores the voltage of the grid to normal levels. D-SMES systems enable operators to increase large-scale power flow through existing transmission lines, significantly increasing grid asset utilization. D-SMES systems are also a cost-effective and readily deployable solution. Given these factors and the current federal emphasis on increasing transmission capacity and reducing related regulatory hurdles, we expect demand for D-SMES systems by utilities and transmission companies to grow as investment in grid infrastructure increases and regulatory barriers fall.

D-VAR

Our Dynamic VAR (D-VAR) product offers a powerful yet cost-effective way of regulating and stabilizing voltage levels by injecting reactive power (VARs) into the grid at precise locations where voltage problems can occur. A D-VAR system is based on our proprietary PowerModule power converters. The primary difference between the D-VAR and D-SMES systems is that a D-VAR system does not contain a SMES device. The decision of whether to incorporate a SMES device into a grid reliability solution is dependent on site specific issues. This flexibility enables us to provide the most cost-effective solution for each application.

Transmission Planning Capabilities: Our Power Electronic Systems business unit has in-depth knowledge of and extensive experience in the design and structure of transmission and distribution grids. Its Transmission Planning Group uses sophisticated software programs to perform analyses of the effects of disturbances in power grids to determine grid reliability under normal and peak loading conditions. This group also analyzes the effects of the incorporation of standard technologies such as capacitors and static VAR compensators (SVCs) and advanced technologies such as HTS cables, D-SMES systems, D-VAR systems and HTS synchronous condensers into power grids. They perform similar analyses to determine the optimum power quality solution for industrial manufacturing sites. Our Transmission Planning Group plays a significant role in the sales and marketing of AMSC's power electronic systems products and solutions.

Manufacturing, Sales and Marketing of Power Electronic Systems: Our Power Electronic Systems business unit operates out of facilities in New Berlin and Middleton, Wisconsin. In New Berlin, we design, develop and test our PowerModule power electronic converters in a state-of-the-art 50,000-square-foot facility. We outsource the manufacture of PowerModule power converters allowing us to focus on our core competency of design and final test of PowerModule systems. In our Middleton operation, we assemble and test components and PowerModule power converters for incorporation into our integrated power electronic systems such as D-SMES, D-VAR and PQ-IVR systems. We made a decision to outsource the manufacture of the superconductor magnets allowing us to focus on our core competency of integrating components for our commercial power quality and reliability systems.

In April 2000, we entered into a co-marketing and sales alliance with GE Industrial Systems (GEIS), a business of the General Electric Corporation, to market and sell co-branded D-SMES systems. GEIS has been our exclusive channel to U.S. utilities for the last three years for D-SMES solutions. When we introduced the D-VAR product in May 2002, GEIS also became our exclusive channel to U.S. utilities for this new product, which is also co-branded when sold to U.S. utilities. Our joint sales and marketing tactics include calls on customers using members of both the AMSC and GEIS direct and regional sales teams. We believe the addition of the GEIS sales teams adds significant strength to our sales efforts. During fiscal 2003, we sold co-branded D-VAR systems to PacifiCorp, BC Hydro, Northeast Utilities, Rayburn Country Electric and Illinois Power.

We also intend to jointly sell co-branded PQ-IVR systems with GEIS to certain industrial customers. Although we have jointly called on industrial customers and have provided sales quotes to several potential industrial customers, we have not yet closed a joint order for a PQ-IVR system. We believe this is due primarily

to the slow-down in the economy over the last several years, which has forced many industrial customers to defer purchases of capital equipment.

Under our co-marketing and sales agreement with GEIS, we sell integrated system to GEIS at a normal margin for the particular product and GEIS then sells the integrated system to the end customer typically with auxiliary equipment such as capacitor banks, transformers and switch gear.

In June 2003, we agreed to extend our co-marketing and sales alliance with GEIS for an additional three years under generally the same terms that were previously in place.

In September 2002 we signed a sales and marketing agreement with Singapore-based Bridex Technologies. This agreement provides our channel for marketing our integrated power electronic systems in the Asia/Pacific region.

Our sales of individual PowerModule power converters are managed by our direct sales force in the U.S. and in Europe. We have sold and intend to sell both individual PowerModules as well as integrated PowerModules for applications such as motor drives, uninterruptible power supplies, wind turbines, and distributed generation applications.

Competition for Power Electronic Systems: We face competition from other companies selling power reliability products, such as SVC (Static Var Compensator) and STATCOM (Static Reactive Compensation) produced by ABB, Alstom, Siemens and Mitsubishi Electric Power Products, Inc., dynamic voltage restorers produced by companies such as S&C Electric Company and ABB, and flywheels and battery-based UPS systems offered by various companies around the world. We do not know of any companies currently developing or selling commercial SMES products; however, there are at least two organizations developing SMES products, a government-sponsored program in Japan and ACCEL Instruments GmbH in Germany.

We face competition from companies that are developing power electronic converters for use in applications that we expect to compete with our PowerModule products. These companies include Ecostar, Inverpower, SatCon, Semikron and Xantrex.

Many of our competitors have substantially greater financial resources, research and development, manufacturing and marketing capabilities than we do. In addition, as the power quality and reliability markets develop, other large industrial companies may enter these fields and compete with us.

Patents, Licenses and Trade Secrets

HTS Patent Background

Since the discovery of high temperature superconductors in 1986, the HTS industry has been characterized by rapid technical advances, which in turn have resulted in a large number of patents, including overlapping patents, relating to superconductivity being applied for and granted worldwide. As a result, the patent situation in the field of HTS technology and products is unusually complex.

An important part of our business strategy is to develop a strong patent position in all of our technology areas. Our patent portfolio comprises both patents we own and patents we license from others. We devote substantial resources to building a strong patent position and we believe that we have significantly strengthened our position in the past several years. As of March 31, 2003, we owned (either alone or jointly) more than 125 U.S. patents—as compared to more than 95 as of March 31, 2002—and had 65 U.S. patent applications (jointly or solely owned) on file. We also hold licenses from third parties covering over 70 issued U.S. patents and 14 U.S. patent applications. Together with the international counterparts of each of these patents, patent applications

[Table of Contents](#)

and licenses, we own more than 430 patents and patent applications worldwide, and have rights through exclusive and non-exclusive licenses to more than 150 additional patents and patent applications. We believe that our current patent position, together with our expected ability to obtain licenses from other parties to the extent necessary, will provide us with sufficient proprietary rights to develop and sell our products. However, for the reasons described below, there can be no assurance that this will be the case.

Despite the strength of our patent position, a number of U.S. and foreign patents and patent applications of third parties relate to our current products, to products we are developing, or to technology we are now using in the development or production of our products. We may need to acquire licenses to those patents, or to successfully contest the scope or validity of those patents, or to design around patented processes or applications.

If companies holding patents or patent applications that we need to license are competitors, we believe the strength of our patent portfolio will significantly improve our ability to enter into license or cross-license arrangements with these companies. However, there can be no assurance that we will be able to obtain all necessary licenses from competitors on commercially reasonable terms, or at all.

We may be required to obtain licenses to some patents and patent applications held by companies or other institutions, such as national laboratories or universities, not directly competing with us. Those organizations may not be interested in cross-licensing or, if willing to grant licenses, may charge unreasonable royalties. We have successfully obtained licenses from a number of such organizations, including Lucent Technologies, Superlink of New Zealand, ORNL, MIT, and Toshiba in Japan, with royalties we consider reasonable. Based on past experience, we expect that we will be able to obtain other necessary licenses on commercially reasonable terms. However, there can be no assurance that we will be able to do so.

Failure to obtain all necessary licenses upon reasonable terms could significantly reduce the scope of our business and have a materially adverse effect on our results of operations. We do not now know the likelihood of successfully contesting the scope or validity of patents held by others. In any event, we could incur substantial costs in challenging the patents of other companies. Moreover, the nature of HTS patents is such that third parties are likely to challenge some of our patents or patent applications, and we could incur substantial costs in defending the scope and validity of our own patents or patent applications whether or not a challenge is ultimately successful.

Choice of HTS Materials

At any given time, we will have a preference for using one or a few specific HTS materials in the production of our products. Any HTS material we use is likely to be covered by one or more patents or patent applications held by other parties.

We have obtained licenses to patents and patent applications covering some HTS materials, including an exclusive license from Superlink and non-exclusive licenses from Lucent Technologies and Toshiba. However, we may have to obtain additional licenses to HTS materials.

HTS Wire Processing and Wire Architecture

We are concentrating on two main methods for processing HTS materials into wire. One produces multi-filamentary composite wire and the other produces coated conductor composite wire. Our strategy is to obtain a proprietary position in each of these methodologies through a combination of patents, licenses and proprietary know-how. If alternative processes become more promising in the future, we will also seek to develop a proprietary position in these alternative processes.

We have filed a number of patent applications that are applicable to multi-filamentary and coated conductor composite wire architectures. Some of these applications have been issued as patents in the United States and

[Table of Contents](#)

abroad, while others are pending. We have acquired an exclusive license from MIT and a non-exclusive license from Oak Ridge National Laboratories to intellectual property relating to coated conductors, and a non-exclusive license from Lucent Technologies and Toshiba relating to the production of multi-filamentary composite wire. We have acquired certain intellectual property rights in the coated conductor area through our collaboration with EPRI.

We have an exclusive license from MIT under an issued U.S. patent that covers the architecture of multi-filamentary (1G) and coated conductor (2G) composite wire, specifically the composite of HTS ceramics and noble metals such as silver. The scope of this patent was the subject of an action in the U.S. District Court of Massachusetts. In September 2002, the court ruled in our favor. We also filed for patents on laminate structures for this wire and on new architectures for coated conductor wire.

A number of other companies have also filed patent applications, and in some instances these have become issued patents, on various aspects of wire processing and wire architecture. To the extent that any of these issued or pending patents might cover the wire processing methodologies or wire architectures we use, we may be required to obtain licenses under those patents; however, there is no assurance that we will be able to do so.

HTS Component and Subsystem Fabrication Patents; HTS Application Patents

We have received several patents and filed a significant number of additional patent applications regarding:

- The design and fabrication of electromagnetic coils and electromagnets;
- The integration of these products with an appropriate coolant or cryocooler;
- The application of these products to specific end uses; and
- HTS motor, generator and synchronous condenser designs.

Since the HTS rotating machine field is relatively new, we believe we are building a particularly strong patent position in this area. A number of other companies have also filed, and in some instances have received, patents on various applications of HTS component and subsystem fabrication methods. If any existing or future patents cover any of these aspects of our operations, we may be required to obtain licenses under those patents.

Power Electronic Systems

We have received several patents and filed a significant number of additional patent applications on power quality and reliability systems, including the D-SMES concept. We have acquired a non-exclusive license from Argonne National Laboratory on a cryogenic connector for SMES applications. We believe we have a strong patent position in the SMES area, and have also filed a series of patents on our proprietary power electronic modules. We have licensed some of our patents specifically on SMES to third parties.

Trade Secrets

Some of the important technology used in our operations and products is not covered by any patent or patent application owned by or licensed to us. However, we take steps to maintain the confidentiality of this technology by requiring all employees and all consultants to sign confidentiality agreements and by limiting access to confidential information. However, no assurance can be given that these measures will prevent the unauthorized disclosure or use of that information. In addition, there is no assurance that others, including our competitors, will not independently develop the same or comparable technology that is one of our trade secrets.

[Table of Contents](#)

Employees

As of March 31, 2003, we employed a total of 297 persons, 31 of whom have Ph.D.s in materials science, physics or related fields. None of our employees are represented by a labor union. Retaining our key employees is important for achieving our goals and we are committed to developing a working environment that motivates and rewards our employees. At the present time, we believe that we have good relations with our employees.

Available Information

American Superconductor's Internet address is www.amsuper.com. The contents of our website are not part of this Annual Report on Form 10-K, and our Internet address is included in this documents as an inactive textual reference only. We make our Annual Reports on Form 10-K, Quarterly Reports on Form 10-Q, Current Reports on Form 8-K and all amendments to those reports available free of charge through our website as soon as reasonably practicable after we file such reports with, or furnished such reports to, the SEC.

Item 2. *Properties*

We operate out of two facilities in Westborough, Massachusetts with a combined total of approximately 129,000 square feet of space. The Two Technology Drive facility in Westborough is under a lease that expires on May 31, 2009. The 121 Flanders Road facility is under a lease that expires on September 30, 2005.

On December 7, 2001, we completed construction and took occupancy of a company-owned 355,000-square-foot HTS wire manufacturing facility located at the Devens Commerce Center in Devens, Massachusetts.

We also operate out of facilities located in Middleton and New Berlin, Wisconsin with a combined total of approximately 83,000 square feet of space. The Middleton, Wisconsin facility comprises approximately 33,000 square feet of space in a building with a lease that expires on December 31, 2004. The New Berlin, Wisconsin facility comprises approximately 50,000 square feet of space under a lease that expires on September 30, 2011.

We decided to outsource our future requirements for LTS magnets used in our SMES systems, allowing us to focus on our core competency of integrating components for our commercial power quality and reliability systems. As a result, we have ceased operations in a second building in Middleton, Wisconsin comprising approximately 27,000 square feet.

Item 3. *Legal Proceedings*

We are not involved in any legal proceedings other than routine litigation or related proceedings incidental to our business that we do not consider material.

Item 4. *Submission of Matters to a Vote of Security Holders*

No matters were submitted to a vote of our security holders during the fourth quarter of the fiscal year ended March 31, 2003.

EXECUTIVE OFFICERS

The tables and biographical summaries set forth below contain certain information with respect to our executive officers as of June 9, 2003:

<u>Name</u>	<u>Age</u>	<u>Position</u>
Gregory J. Yurek	56	President, Chief Executive Officer and Chairman of the Board of Directors
Kevin M. Bisson	42	Senior Vice President and Chief Financial Officer
Ross S. Gibson	44	Vice President and Chief Administrative Officer
Alexis P. Malozemoff	59	Executive Vice President and Chief Technical Officer
Charles W. Mayer	57	Vice President and General Manager, SuperMachines Business Unit
David Paratore	35	Senior Vice President and General Manager, AMSC Wires Business Unit
Thomas M. Rosa	50	Vice President of Finance and Accounting
Charles W. Stankiewicz	44	Vice President and General Manager, Power Electronic Systems Business Unit

Gregory J. Yurek co-founded American Superconductor in 1987 and has been president since March 1989, chief executive officer since December 1989 and chairman of the board of directors since October 1991. Dr. Yurek also served as vice president and chief technical officer from August 1988 until March 1989 and as chief operating officer from March 1989 until December 1989. Prior to joining American Superconductor, Dr. Yurek was a professor of Materials Science and Engineering at MIT for 12 years. Dr. Yurek has been a director of American Superconductor since 1987.

Kevin M. Bisson joined American Superconductor in May 2003 as senior vice president and chief financial officer. Prior to joining American Superconductor, Mr. Bisson was vice president, controller and treasurer for Axcelis Technologies, Inc., a semiconductor equipment manufacturing company, from 2000 to 2003. From 1989 to 2000, Mr. Bisson held several senior financial positions with Hamilton Sundstrand, Hamilton Standard and Carrier Corporation, all units of United Technologies Corporation, a multi-national conglomerate.

Ross S. Gibson joined American Superconductor in July 1997 as vice president, Human Resources. From December 2000 to March 2001, Mr. Gibson was vice president of Human Resources at Workscape, a human resource management software company. From March 2001 to June 2001, Mr. Gibson was an independent management consultant. In July 2001, Mr. Gibson returned to American Superconductor as vice president and chief administrative officer. He is responsible for the strategic direction of corporate human resources, corporate governance, corporate services and general administration. Previously, Mr. Gibson was vice president, Human Resources and Administration, chief administrative officer for Cambridge NeuroScience, Inc., a development stage biotechnology company. During his 18 years in human resources and services, he also held positions at Lifeline Systems, Lotus Development and General Motors.

Alexis P. Malozemoff joined American Superconductor as vice president, Research and Development in January 1991 and was elected our chief technical officer in January 1993 and senior vice president in May 1998. In May 2003, Dr. Malozemoff was appointed executive vice president in addition to retaining the position of chief technical officer. Prior to joining American Superconductor, Dr. Malozemoff spent 19 years at IBM in a variety of research and management positions, most recently as IBM's research coordinator for High Temperature Superconductivity.

Charles W. Mayer joined American Superconductor in February 2002 as director of programs and product management for the SuperMachines business unit. In June 2003, Mr. Mayer was appointed vice president and

[Table of Contents](#)

general manager of the SuperMachines business unit. From 1998 to 2001, Mr. Mayer was director of Nuclear Projects at Exelon, an energy services company. Prior to Exelon, Mr. Mayer completed a 28 year career in the U.S. Navy.

David Paratore joined American Superconductor in November 2000 as vice president, Strategic Business Development. From December 2000 to November 2001, Mr. Paratore ran the company's new Integrated Electronics business in Milwaukee, a business that was later integrated into AMSC's Power Electronic Systems business in March 2002. In November 2001, Mr. Paratore was appointed to position of vice president and general manager of the SuperMachines Business Unit. In June 2003, Mr. Paratore was appointed senior vice president and general manager, AMSC Wires Business Unit. In 2000, Mr. Paratore was an account executive for GROWTTH[®] Consulting where he provided operations, distribution and new product introduction consulting services to leading companies in the consumer product and industrial manufacturing industries. Prior to GROWTTH, Mr. Paratore held increasingly senior positions with Pratt & Whitney, a division of United Technologies Corp, and most recently, he was the general manager responsible for the startup of the V2500 aircraft engine overhaul facility.

Thomas M. Rosa joined American Superconductor in October 1992 as corporate controller and was elected our chief accounting officer and assistant secretary in July 1998. In May 2003, Mr. Rosa was appointed vice president of Finance and Accounting. Prior to joining American Superconductor, Mr. Rosa spent ten years in a variety of financial management positions at Prime Computer, Wang Laboratories, Lockheed Sanders and most recently, was the division controller at Prime Computer.

Charles W. Stankiewicz joined American Superconductor in July 1998 as general manager of our SMES Business Unit, based in Madison, Wisconsin. In March 2002, Mr. Stankiewicz was appointed to his current position as general manager of the Power Electronic Systems business unit. Prior to joining American Superconductor, Mr. Stankiewicz held senior positions for ten years at ABB, a Swiss industrial conglomerate. From 1980 to 1989, Mr. Stankiewicz was with Westinghouse Electric as a regional service manager and special sales representative for the power generation business, focused on major electric utilities.

PART II**Item 5. Market for Registrant's Common Stock and Related Stockholder Matters**

Our Common Stock has been quoted on the NASDAQ National Market under the symbol "AMSC" since 1991. The following table sets forth the high and low price per share of our Common Stock as reported on the NASDAQ National Market for the two most recent fiscal years:

	Common Stock Price	
	High	Low
Fiscal year ended March 31, 2002:		
First quarter	27.90	10.75
Second quarter	24.50	8.35
Third quarter	14.00	8.65
Fourth quarter	13.58	6.50
Fiscal year ended March 31, 2003:		
First quarter	8.87	3.85
Second quarter	6.05	2.65
Third quarter	4.24	2.10
Fourth quarter	5.41	3.02

The number of shareholders of record on June 6, 2003 was 676.

Dividend Policy

We have never paid cash dividends on our common stock. We currently intend to retain earnings, if any, to fund the development and growth of our business and do not anticipate paying cash dividends for the foreseeable future. Payment of future cash dividends, if any, will be at the discretion of our board of directors after taking into account various factors, including our financial condition, operating results, current and anticipated cash needs and plans for expansion.

Item 6. Selected Financial Data

The selected consolidated financial data presented below for the fiscal years ended March 31, 2003, 2002, 2001, 2000, and 1999 have been derived from our consolidated financial statements that have been audited by PricewaterhouseCoopers LLP, our independent accountants. This financial data should be read in conjunction with the Consolidated Financial Statements and the Notes thereto and the other financial information appearing elsewhere in this Annual Report on Form 10-K.

	Year ended March 31,				
	2003	2002	2001	2000	1999
	(In thousands, except per share data)				
Revenues	21,020	11,650	16,768	15,113	11,257
Net loss	(87,633)	(56,985)	(21,676)	(17,598)	(15,326)
Net loss per share	(4.21)	(2.79)	(1.08)	(1.11)	(1.01)
Total assets	101,979	197,795	239,927	248,914	48,130
Working capital	19,407	36,834	108,808	135,681	30,459
Cash, cash equivalents and long-term marketable securities	20,049	68,200	160,225	218,655	31,572
Stockholders' equity	87,819	172,166	227,564	240,944	43,958

[Table of Contents](#)

Item 7. *Management's Discussion and Analysis of Financial Condition and Results of Operations*

The information required by this Item is attached as *Appendix A* hereto and is incorporated herein by reference.

Item 7A. *Quantitative and Qualitative Disclosures About Market Risk*

Our exposure to market risk through financial instruments, such as investments in marketable securities, is not material.

Item 8. *Financial Statements and Supplementary Data*

All financial statements required to be filed hereunder are filed as *Appendix B* hereto, are listed under Item 15(a), and are incorporated herein by reference.

Item 9. *Changes in and Disagreements with Accountants on Accounting and Financial Disclosure*

Not Applicable.

PART III

Item 10. *Directors and Executive Officers of the Registrant*

The response to this item is contained in part under the caption “Executive Officers” in Part I of this Annual Report on Form 10-K, and in part in our Proxy Statement for the Annual Meeting of Stockholders for the fiscal year ended March 31, 2003 (the “2003 Proxy Statement”) in the sections “Election of Directors—Nominees,” and “Section 16(a) Beneficial Ownership Reporting Compliance,” which sections are incorporated herein by reference.

Item 11. *Executive Compensation*

The response to this item is contained in the 2003 Proxy Statement in the sections “—Executive Compensation,” “—Employment Agreements with Senior Executives,” “—Board and Committee Meetings” and “—Compensation Committee Interlocks and Insider Participation,” which sections are incorporated herein by reference.

Item 12. *Security Ownership of Certain Beneficial Owners and Management and Related Stockholder Matters*

The response to this item is contained in the 2003 Proxy Statement in the sections “Beneficial Ownership of Common Stock” and “Equity Compensation Plan Information,” which sections are incorporated herein by reference.

Item 13. *Certain Relationships and Related Transactions*

Not applicable.

Item 14. *Controls and Procedures*

a) *Evaluation of disclosure controls and procedures.* Based on their evaluation of our disclosure controls and procedures (as defined in Rules 13a-14(c) and 15d-14(c) under the Securities Exchange Act of 1934) as of a date within 90 days of the filing date of this Annual Report on Form 10-K, our chief executive officer and chief financial officer have concluded that our disclosure controls and procedures are designed to ensure that information required to be disclosed by us in the reports that we file or submit under the Exchange Act is recorded, processed, summarized and reported within the time periods specified in the SEC’s rules and forms and are operating in an effective manner.

b) *Changes in internal controls.* There were no significant changes in our internal controls or in other factors that could significantly affect these controls subsequent to the date of their most recent evaluation.

PART IV

Item 15. Exhibits, Financial Statement Schedules, and Reports on Form 8-K

(a) The following documents are filed as *Appendix B* hereto and are included as part of this Annual Report on Form 10-K:

(1) Financial Statements:

Report of Independent Accountants
Consolidated Balance Sheets
Consolidated Statements of Operations
Consolidated Statements of Comprehensive Loss
Consolidated Statements of Cash Flows
Consolidated Statements of Changes in Stockholders' Equity
Notes to Consolidated Financial Statements

(2) Financial Statement Schedules:

Schedule II — Valuation and Qualifying Accounts for fiscal years ended March 31, 2003, 2002, and 2001.

All other schedules for which provision is made in the applicable regulation of the Securities and Exchange Commission are not required under the related instructions or are inapplicable, and therefore have been omitted.

(b) *Reports on Form 8-K*

No reports on Form 8-K were filed during the last quarter of our fiscal year ended March 31, 2003.

(c) The list of Exhibits filed as a part of this Annual Report on Form 10-K is set forth on the Exhibit Index immediately preceding such Exhibits, and is incorporated herein by reference.

AMERICAN SUPERCONDUCTOR CORPORATION
MANAGEMENT'S DISCUSSION AND ANALYSIS OF FINANCIAL
CONDITION AND RESULTS OF OPERATIONS

American Superconductor Corporation was founded in 1987. We are focused on developing, manufacturing and selling products using two core technologies: high temperature superconductor ("HTS") wires and power electronic converters for electric power applications. We also assemble superconductor wires and power electronic converters into fully-integrated products, such as HTS ship propulsion motors and dynamic reactive compensation systems, which we sell or plan to sell to end users.

Critical Accounting Policies

The preparation of consolidated financial statements requires that we make estimates and judgments that affect the reported amounts of assets, liabilities, revenue and expenses, and related disclosure of contingent assets and liabilities. We base our estimates on historical experiences and various other assumptions that are believed to be reasonable under the circumstances, the results of which form the basis for making judgments about the carrying values of assets and liabilities that are not readily apparent from other sources. Actual results may differ under different assumptions or conditions.

Our accounting policies that involve the most significant judgments and estimates are as follows:

- Revenue recognition;
- Long-term inventory and deferred revenue;
- Allowance for doubtful accounts;
- Long-lived assets;
- Inventory accounting;
- Deferred tax assets; and
- Acquisition accounting.

Revenue recognition. For certain arrangements, such as contracts to perform research and development and prototype development contracts, we record revenues using the percentage of completion method, measured by the relationship of costs incurred to total estimated contract costs. We follow this method since reasonably dependable estimates of the revenue and costs applicable to various stages of a contract can be made. Since many contracts extend over a long period of time, revisions in cost and funding estimates during the progress of work have the effect of adjusting earnings applicable to performance in prior periods in the current period. Recognized revenues and profit or loss are subject to revisions as the contract progresses to completion. Revisions in profit or loss estimates are charged to income in the period in which the facts that give rise to the revision become known.

We recognize revenue from product sales upon shipment, installation or acceptance, where applicable, provided persuasive evidence of an arrangement exists, delivery has occurred, the sales price is fixed or determinable and the collectibility is reasonably assured, or for some programs, on the percentage of completion method of accounting. When other significant obligations remain after products are delivered, revenue is recognized only after such obligations (including buyback provisions) are fulfilled.

Long-term inventory and deferred revenue. Long-term inventory of \$3,250,000 represents SMES units that were delivered in fiscal 2001 to one of our customers, Wisconsin Public Service Corporation ("WPS") for a total purchase price of \$3,787,000, less \$537,000 recorded as revenue in the quarter ended December 31, 2002. As the sale of these units is subject to certain return and buyback provisions which expire from 2002 to 2009, we are deferring recognition of the revenue related to the remaining \$3,250,000 in sales until the applicable buyback

AMERICAN SUPERCONDUCTOR CORPORATION
MANAGEMENT'S DISCUSSION AND ANALYSIS OF FINANCIAL
CONDITION AND RESULTS OF OPERATIONS—(Continued)

provisions lapse. Long-term deferred revenue of \$3,250,000 represents the \$3,787,000 cash payment received from WPS related to this transaction, less \$537,000 recorded as revenue in the third quarter of fiscal 2003. The buyback provisions, which are subject to a minimum 6-month written notice requirement, began to lapse in the quarter ended December 31, 2002, until which time WPS had the right to return all the units for the full purchase price of \$3,787,000. On December 31 of each year after 2002, WPS has the right, subject to a minimum 6-month notice requirement, to sell the units back to us at a reduced price. Between January 1, 2003 and the next annual buyback date of December 31, 2003, the repurchase price for the units will be \$3,250,000 and that price is further reduced by approximately 12% per year through December 31, 2009. We recorded \$537,000 of revenue and an equal amount of cost of revenue in the quarter ended December 31, 2002, as the buyback price transitioned from \$3,787,000 to \$3,250,000. We also recorded a \$537,000 reduction in long-term inventory and long-term deferred revenue.

Allowance for doubtful accounts. If the financial condition of our customers were to deteriorate, resulting in an impairment of their ability to make payments, additional provisions for bad debt allowances may be required. We provided for an allowance for doubtful accounts of \$2,624,000 in fiscal 2003 and \$727,000 in fiscal 2002 relating to two Power Electronics Systems receivables.

Long-Lived Assets. We periodically evaluate our long-lived assets for potential impairment under SFAS No. 144, "Accounting for the Impairment or Disposal of Long-Lived Assets." We perform these evaluations whenever events or circumstances suggest that the carrying amount of an asset or group of assets is not recoverable. Our judgments regarding the existence of impairment indicators are based on market and operational performance. Indicators of potential impairment include:

- a significant change in the manner in which an asset is used;
- a significant decrease in the market value of an asset;
- a significant adverse change in its business or the industry in which it is sold;
- a current period operating cash flow loss combined with a history of operating or cash flow losses or a projection or forecast that demonstrates continuing losses associated with the asset; and
- Significant advances in our technologies that require changes in our manufacturing process.

If we believe an indicator of potential impairment exists, we test to determine whether impairment recognition criteria in SFAS No. 144 have been met. To analyze a potential impairment, we project undiscounted future cash flows over the remaining life of the asset or the primary asset in the asset group. If these projected cash flows are less than the carrying amount, an impairment loss is recognized based on the fair value of the asset or asset group less any costs of disposition. Evaluating the impairment requires judgment by our management to estimate future operating results and cash flows. If different estimates were used, the amount and timing of asset impairments could be affected. We charge impairments of the long-lived assets to operations if our evaluations indicate that the carrying values of these assets are not recoverable.

AMERICAN SUPERCONDUCTOR CORPORATION
MANAGEMENT'S DISCUSSION AND ANALYSIS OF FINANCIAL
CONDITION AND RESULTS OF OPERATIONS—(Continued)

On the basis of the probability-weighted discounted cash flow analysis, we deemed it necessary to take a \$39,231,000 impairment charge to write down the 1G asset group to an estimated current fair value.

Inventory accounting. We write down inventory for estimated obsolescence or unmarketable inventory in an amount equal to the difference between the cost of the inventory and the estimated realizable value based upon assumptions of future demand and market conditions. If actual market conditions are less favorable than those projected, additional inventory write-downs may be required. In fiscal 2003 and 2002, we recorded \$3,421,000 and \$3,464,000, respectively, of charges related to our magnet inventory at our Power Electronic Systems business unit in Wisconsin to write it down to an estimated realizable value. While we will continue to offer and physically maintain low temperature superconductor storage devices (which include magnets) in Wisconsin, none of our sales of integrated power electronic systems during fiscal 2003 included such storage devices.

Deferred tax assets. We have recorded a full valuation allowance to reduce our deferred tax assets to the amount that is more likely than not to be realized. While we consider future taxable income and tax planning strategies in assessing the need for the valuation allowance, if management were to determine that we would be able to realize deferred tax assets in the future in excess of the net recorded amount, an adjustment to the deferred tax asset would increase income in the period such determination was made. Likewise, should we determine that we would not be able to realize all or part of our net deferred tax assets in the future, an adjustment to the deferred tax asset would decrease income in the period such determination was made.

Goodwill. Goodwill represents the excess of cost over net assets of acquired businesses that are consolidated. Pursuant to Statement of Financial Accounting Standards (SFAS) No. 142 "Goodwill and Other Intangible Assets", goodwill is not amortized. In lieu of amortization, we perform an impairment review of our goodwill at least annually or when events and changes in circumstances indicate the need for such a detailed impairment loss analysis, as prescribed by SFAS 142. To date, we have determined that goodwill is not impaired, but we could in the future determine that goodwill is impaired, which would result in a charge to earnings.

Acquisition accounting. We account for our acquisitions under the purchase method of accounting pursuant to SFAS No. 141 "Business Combinations". In June 2000, we acquired in a business combination substantially all of the assets of Integrated Electronics, LLC ("IE"), as well as IE's employees and facility lease. The IE acquisition was accounted for under the purchase method of accounting. Goodwill of \$1,329,282 represented the excess of the purchase price of \$1,833,125 over the fair value of the acquired assets of \$503,843 at June 1, 2000. Goodwill was \$1,107,735 at March 31, 2003 and March 31, 2002, reflecting amortization in fiscal year 2001 of \$221,547.

Impairment/Other Charges (Fiscal Year 2003)

For fiscal 2003, we recorded a \$39,231,000 impairment charge primarily on our building and equipment assets in Devens, Massachusetts, in connection with our plans to transition over the next three or four years to a lower cost, 2G HTS wire manufacturing methodology. The impairment charge was recorded in accordance with SFAS No. 144, "Accounting for the Impairment or Disposal of Long-Lived Assets".

In addition, we recorded other charges in March 2003 of \$3,421,000 relating to an increase in magnet inventory reserves at our Power Electronic Systems business unit in Wisconsin, which was reported in Costs of revenue—product sales and prototype development contracts, and \$2,624,000 relating to an increase in the allowance for doubtful accounts to cover a Power Electronics System receivable which was reported under Selling, general, and administrative expense. We are continuing our efforts to collect this receivable.

AMERICAN SUPERCONDUCTOR CORPORATION
MANAGEMENT'S DISCUSSION AND ANALYSIS OF FINANCIAL
CONDITION AND RESULTS OF OPERATIONS—(Continued)

Restructuring/Pirelli/Other Charges (Fiscal Year 2002)

In March 2002, we announced a series of restructuring, consolidation and cost-cutting measures to create a more streamlined and flatter organization aimed at reducing our cost structure as we drive to commercialize our technologies and products. The restructuring resulted in the reduction of 99 full-time employees across all business functions at our Massachusetts and Wisconsin locations. Our Power Quality and Reliability business unit, based in Middleton, WI, and Power Electronics business unit, based in New Berlin, WI, were combined into a new business unit called Power Electronic Systems. This change leveraged personnel with similar skills in the two business units and significantly reduced the cost structure. As part of the restructuring, we also announced that we will outsource our future requirements for low temperature superconductor (LTS) magnets used in our SMES systems and as a result, we discontinued operations in one of our two buildings in Middleton, WI that comprises approximately 27,000 square feet. Cash payments related to the workforce reduction were substantially completed in the first quarter of fiscal 2003. Exit costs related to the leased facility are being incurred over the 18-month period ending in December 2003. In addition to restructuring charges of \$5,666,000 we recorded other charges in March 2002 of \$727,000 relating to an increase in allowance for doubtful accounts, \$3,464,000 for an inventory write-down and \$4,010,000 relating to the Pirelli license agreement.

RESULTS OF OPERATIONS

Fiscal Years Ended March 31, 2003 and March 31, 2002*Revenues*

Total consolidated revenues increased to \$21,020,000 in fiscal 2003 from \$11,650,000 in fiscal 2002, an increase of \$9,370,000 or 80.4%.

<u>Revenues</u>	<u>2003</u>	<u>2002</u>
Power Electronic Systems	\$ 10,934,000	\$ 1,416,000
SuperMachines	6,125,000	5,840,000
AMSC Wires	3,961,000	4,394,000
Total	\$ 21,020,000	\$ 11,650,000

Power Electronic Systems business unit sales, which include D-VAR integrated power electronic systems and power electronic converters, were \$10,934,000 in fiscal 2003 compared to \$1,416,000 in fiscal 2002, an increase of \$9,518,000. Power Electronic Systems sales for fiscal 2003 included multiple D-VAR system sales to Northeast Utilities and Rayburn Electric, and additional system sales to BC Hydro and Pacificorp, compared to one D-VAR sale in fiscal 2002 to the Tennessee Valley Authority (TVA). In addition, the Power Electronics Systems business unit recognized \$2,121,000 of prototype development contract revenues in connection with work performed on our U.S. Navy contract on Power Electronic Building Blocks (PEBB) in fiscal 2003, compared to \$197,000 in fiscal 2002.

Our SuperMachines (formerly known as Electric Motors and Generators) business unit recognized revenues of \$6,125,000 in fiscal 2003, an increase of \$285,000 or 4.9% over fiscal 2002 revenues of \$5,840,000. This was the result of higher prototype development contract revenues associated with fiscal 2003 work performed on the 5 Megawatt (MW) and 36.5 MW HTS motor contracts with the U.S. Navy, the second of which was awarded in March 2003. On March 3, 2003, we announced the receipt of a three-year \$70 million contract from the U.S. Navy for the delivery of a 36.5 (MW) high temperature superconductor propulsion motor for electric warships. In

AMERICAN SUPERCONDUCTOR CORPORATION
MANAGEMENT'S DISCUSSION AND ANALYSIS OF FINANCIAL
CONDITION AND RESULTS OF OPERATIONS—(Continued)

the first month of work on this incrementally funded contract, we recognized revenues of \$1,185,000 on the 36.5 MW motor program. We expect SuperMachines business unit revenues to be significantly higher in fiscal 2004 (ending March 31, 2004) than they were in fiscal 2003, based on the receipt of this new cost plus incentive fee contract from the U.S. Navy. As of March 31, 2003, incremental funding of \$14,348,000 had been allotted to this contract.

Revenues in our AMSC Wires (formerly known as HTS Wire) business unit were \$3,961,000 in fiscal 2003 compared to \$4,394,000 in fiscal 2002, a decrease of \$433,000 or 9.9% caused primarily by a \$1,396,000 reduction in contract revenues, partially offset by a \$963,000 increase in product sales in fiscal 2003. Pirelli Energy Cables and System provided us with \$1,500,000 of research and development funding in fiscal 2002, but no funding in fiscal 2003, causing the decline in contract revenues. This discontinuance of Pirelli funding in fiscal 2003 was the result of a license agreement signed with Pirelli in February 2002 which allows us to sell our HTS wire to other cable manufacturers in addition to Pirelli. AMSC Wires' product sales were \$3,246,000 in fiscal 2003, compared to \$2,283,000 in fiscal 2002. The \$963,000 increase in AMSC Wires' product sales in fiscal 2003 was driven by higher sales of HTS wire in the fourth quarter of fiscal 2003. We expect product sales to continue to increase in this business unit in fiscal 2004 as a result of our selection by the U.S. Department of Energy (DOE) in April 2003 as the prime contractor for an HTS power transmission cable project in the Long Island Power Authority (LIPA) transmission grid. Net of cost share, we expect our AMSC Wires business unit to record approximately \$15,200,000 in revenue (of which approximately \$10,700,000 will be awarded to subcontractors) from this project during the period April 2003 through approximately April 2006.

In addition to reported revenues, we also received funding of \$764,000 in fiscal 2003 under two government cost-sharing agreements, compared to \$603,000 in fiscal 2002. Funding from government cost-sharing agreements is recorded as an offset to Research and development and Selling, general and administrative expenses, as required by government contract accounting guidelines, rather than as revenue. We anticipate that a portion of our funding in the future will continue to come from cost-sharing agreements as we continue to develop joint programs with government agencies. We expect cost sharing funding to continue to increase in fiscal 2004 as compared to fiscal 2003 based on the November 2002 receipt of a \$2,000,000, two-year contract from the Department of Commerce, under which we recorded \$238,000 of cost sharing funding in fiscal 2003.

Costs and expenses

Total costs and expenses for the year ended March 31, 2003 were \$109,532,000 compared to \$73,203,000 for the prior year, an increase of \$36,329,000. These costs and expenses included \$45,276,000 of non-cash charges recorded in the fourth quarter of fiscal 2003 related to an asset impairment, an inventory write-down and an increase in the allowance for doubtful accounts. Fiscal 2002 costs and expenses included \$13,867,000 of charges related to the restructuring and product line consolidation implemented in March 2002 and to the purchase of a license from Pirelli in February 2002. Costs and expenses exclusive of impairment and other charges, which are non-GAAP measures, were \$64,256,000 in fiscal 2003 and \$59,336,000 in fiscal 2002. This increase of \$4,920,000 was primarily due to materials and other outside costs associated with the higher level of fiscal 2003 revenues. We present costs and expenses exclusive of impairment and other charges because we believe this presentation provides investors with a useful view of our operating results by isolating certain charges and describing our performance without them.

"Costs of revenue—product sales and prototype development contracts" increased by \$14,219,000 to \$31,518,000 in fiscal 2003, compared to \$17,299,000 in fiscal 2002, due to higher fiscal 2003 revenues, particularly in the Power Electronic Systems business unit, and the costs related to the AMSC Wires business unit's occupancy of the Devens, MA manufacturing plant. "Costs of revenue—product sales and prototype

AMERICAN SUPERCONDUCTOR CORPORATION
MANAGEMENT'S DISCUSSION AND ANALYSIS OF FINANCIAL
CONDITION AND RESULTS OF OPERATIONS—(Continued)

development contracts” in Power Electronics Systems increased by \$6,121,000 due to higher systems shipments. Devens-related costs (including building and equipment depreciation) increased by \$6,428,000 in fiscal 2003 compared to fiscal 2002, when Devens costs were just beginning to be incurred. “Costs of revenue—product sales and prototype development contracts” also increased due to the higher level of product sales in the AMSC Wires business unit and the higher level of prototype development contract revenues in SuperMachines. “Costs of revenue—contract revenue” decreased proportionally with the lower level of contract revenue.

Pro forma research and development (“R&D”) expenses, which include amounts classified as costs of revenue and amounts offset by cost sharing funding, decreased by \$3,435,000 to \$33,447,000 in fiscal 2003, compared to \$36,882,000 in fiscal 2002. This decrease was primarily the result of reduced R&D spending in the AMSC Wires and Power Electronic Systems business units of \$3,096,000 and \$2,315,000, respectively, related to the reduction in force implemented as part of our March 2002 restructuring, and additional headcount reductions taken in January 2003. These decreases in R&D spending were partially offset by higher R&D spending, both internally and externally funded, in the SuperMachines business unit of \$1,976,000. A portion of the R&D expenditures related to externally funded development contracts has been classified as costs of revenue (rather than as R&D expenses). Additionally, a portion of R&D expenses was offset by cost sharing funding. Net R&D expenses (exclusive of amounts classified as costs of revenues and amounts offset by cost sharing funding) decreased to \$21,940,000 in fiscal 2003 from \$27,814,000 in fiscal 2002.

Our R&D expenditures are summarized as follows:

	Year Ended 3/31/2003	Year Ended 3/31/2002
R&D expenses per Consolidated Statements of Operations	\$ 21,940,000	\$ 27,814,000
R&D expenditures on development contracts classified as Costs of revenue	10,997,000	8,757,000
R&D expenditures offset by cost sharing funding	510,000	311,000
Pro forma R&D expenses	<u>\$ 33,447,000</u>	<u>\$ 36,882,000</u>

Pro forma selling, general, and administrative (“SG&A”) expenses, which include amounts classified as costs of revenue and amounts offset by cost sharing funding, decreased by \$368,000 to \$17,896,000 in fiscal 2003, compared to \$18,264,000 in fiscal 2002. This decrease was primarily the result of the reductions in force implemented as part of our March 2002 restructuring, and additional headcount reductions taken in January 2003, partially offset by the \$2,624,000 increase in the allowance for doubtful accounts recorded in March of 2003. A portion of the SG&A expenditures related to externally funded development contracts has been classified as costs of revenue (rather than as SG&A expenses). Additionally, a portion of SG&A expenses was offset by cost sharing funding. Net SG&A expenses (exclusive of amounts classified as costs of revenue and amounts offset by cost sharing funding) was \$16,159,000 in fiscal 2003 compared to \$16,313,000 in the prior year.

Our SG&A expenditures are summarized as follows:

	Year Ended 3/31/2003	Year Ended 3/31/2002
SG&A expenses per Consolidated Statements of Operations	\$ 16,159,000	\$ 16,313,000
SG&A expenditures on development contracts classified as Costs of revenue	1,482,000	1,659,000
SG&A expenditures offset by cost sharing funding	255,000	292,000
Pro forma SG&A expenses	<u>\$ 17,896,000</u>	<u>\$ 18,264,000</u>

AMERICAN SUPERCONDUCTOR CORPORATION
MANAGEMENT'S DISCUSSION AND ANALYSIS OF FINANCIAL
CONDITION AND RESULTS OF OPERATIONS—(Continued)

We present pro forma R&D and pro forma SG&A expenses, which are non-GAAP measures, because we believe this presentation provides useful information on our aggregate R&D and SG&A spending.

Impairment/Restructuring/Pirelli

An impairment charge was recorded in fiscal 2003 of \$39,231,000 primarily on our building and equipment assets in Devens, Massachusetts, in connection with our plans to transition over the next several years to a lower cost, 2G HTS wire manufacturing methodology.

In fiscal 2002 we recorded \$5,666,000 in restructuring charges and an additional \$4,010,000 charge relating to a Pirelli license cost.

Non-operating expenses/Interest income

Interest income decreased to \$869,000 in fiscal 2003 from \$4,451,000 in fiscal 2002. This decrease in interest income reflects the lower cash balances available for investment as a result of cash being used to fund our operations and to purchase property, plant and equipment, as well as lower interest rates available on our investments. Other income (expense), net was \$10,000 in fiscal 2003, compared to \$117,000 in fiscal 2002, consisting primarily of investment gains from long-term marketable securities.

We expect to continue to incur operating losses until the end of fiscal 2005, as we continue to devote significant financial resources to our research and development activities and commercialization efforts.

We expect to be party to agreements which, from time to time, may result in costs incurred exceeding expected revenues under such contracts. We may enter into such agreements for a variety of reasons including, but not limited to, entering into new product application areas, furthering the development of key technologies, and advancing the demonstration of commercial prototypes in critical market applications.

Please refer to the "Future Operating Results" section below for a discussion of certain factors that may affect our future results of operations and financial condition.

Fiscal Years Ended March 31, 2002 and March 31, 2001

Revenues

Total revenues declined to \$11,650,000 in fiscal 2002 (ended March 31, 2002) from \$16,768,000 in fiscal 2001, a decrease of \$5,118,000. Power Electronic Systems business unit sales, which include SMES systems and power electronic converters, were \$1,416,000 in fiscal 2002 compared to \$9,315,000 in fiscal 2001, a decrease of \$7,899,000. Lower SMES system sales were primarily attributable to adverse economic conditions and uncertain conditions in the electric power industry, which have led to significant delays in orders for capital goods. Revenues from our AMSC Wires business unit were \$4,394,000, a \$551,000 decrease from prior year. AMSC Wires product sales increased by \$258,000 while revenues derived from research contracts with Pirelli and the U.S. Government declined by \$809,000. SuperMachines business unit revenues increased \$3,332,000 to \$5,840,000 as a result of an increase in prototype development contract revenue with the U.S. Navy.

In addition to reported revenues, we also received funding of \$603,000 in fiscal 2002 under a government cost-sharing agreement with the U.S. Air Force, compared to \$262,000 in fiscal 2001. Funding from government

AMERICAN SUPERCONDUCTOR CORPORATION
MANAGEMENT'S DISCUSSION AND ANALYSIS OF FINANCIAL
CONDITION AND RESULTS OF OPERATIONS—(Continued)

cost-sharing agreements is recorded as an offset to research and development and selling, general and administrative expenses ("SG&A"), as required by government contract accounting guidelines, rather than as revenue.

Costs and expenses

Total costs and expenses for the year ended March 31, 2002 were \$73,203,000 compared to \$51,163,000 for the prior year. These costs and expenses included \$13,867,000 of charges recorded in the fourth quarter related to the restructuring and product line consolidation implemented in March 2002 and the purchase of a license from Pirelli Energy Cables & Systems ("Pirelli") announced in February 2002. The restructuring costs of \$5,666,000 included \$1,549,000 of severance and related costs, \$2,826,000 of production and test equipment write-offs related to the decision to outsource magnet requirements for SMES products, \$691,000 of facility exit costs, and \$600,000 of cancelled purchase commitments. We recorded a one-time charge of \$4,010,000 relating to the new license agreement from Pirelli to allow us to sell HTS wire to other cable manufacturers in addition to Pirelli. Included in SG&A was a \$727,000 increase in the allowance for doubtful account reserve related to the product line consolidation. "Costs of revenue—product sales and prototype development contracts" included \$3,464,000 related to a magnet inventory reserve associated with the Power Electronic Systems business unit restructuring. "Costs of revenue—product sales and prototype development contracts" also increased due to the higher level of SuperMachines prototype development contract revenues with the U.S. Navy and increased AMSC Wires product sales, partially offset by lower cost of sales associated with decreased SMES system sales. "Costs of revenue—contract revenue" decreased proportionally with the lower level of contract revenue.

Pro forma research and development ("R&D") expenses, which include amounts classified as costs of revenue and amounts offset by cost sharing funding, increased to \$36,882,000 in fiscal 2002, compared to \$28,846,000 in fiscal 2001. These increases were due to the continued scale-up of our internal research and development activities, particularly in the areas of multi-filamentary composite wire scale-up and power electronic converters, including the hiring of additional personnel and the purchases of materials and equipment, and higher spending on licenses, consultants and outside contractors. A portion of the R&D expenditures related to externally funded development contracts has been classified as costs of revenue (rather than as R&D expenses). Additionally, a portion of R&D expenses was offset by cost sharing funding. Net R&D expenses (exclusive of amounts classified as Costs of revenues and amounts offset by cost sharing funding) increased to \$27,814,000 in fiscal 2002 from \$22,832,000 in fiscal 2001.

Our R&D expenditures are summarized as follows:

	Year Ended 3/31/2002	Year Ended 3/31/2001
R&D expenses per Consolidated Statements of Operations	\$ 27,814,000	\$ 22,832,000
R&D expenditures on development contracts classified as Costs of revenue	8,757,000	5,879,000
R&D expenditures offset by cost sharing funding	311,000	135,000
Pro forma R&D expenses	<u>\$ 36,882,000</u>	<u>\$ 28,846,000</u>

AMERICAN SUPERCONDUCTOR CORPORATION
MANAGEMENT'S DISCUSSION AND ANALYSIS OF FINANCIAL
CONDITION AND RESULTS OF OPERATIONS—(Continued)

Pro forma SG&A expenses, which include amounts classified as Costs of revenue and amounts offset by cost sharing funding, increased to \$18,264,000 in fiscal 2002 from \$16,163,000 in the prior year. These increases were primarily due to the hiring of additional personnel and related expenses incurred to support corporate development, marketing, and recruiting activities and future planned growth, and an increase in the allowance for doubtful accounts. A portion of the SG&A expenditures related to externally funded development contracts has been classified as costs of revenue (rather than as SG&A expenses). Additionally, a portion of SG&A expenses was offset by cost sharing funding. Net SG&A expenses (exclusive of amounts classified as Costs of revenue and amounts offset by cost sharing funding) was \$16,313,000 in fiscal 2002 compared to \$14,215,000 in the prior year.

Our SG&A expenditures are summarized as follows:

	Year Ended 3/31/2002	Year Ended 3/31/2001
SG&A expenses per Consolidated Statements of Operations	\$ 16,313,000	\$ 14,215,000
SG&A expenditures on development contracts classified as Costs of revenue	1,659,000	1,821,000
SG&A expenditures offset by cost sharing funding	292,000	127,000
Pro forma SG&A expenses	<u>\$ 18,264,000</u>	<u>\$ 16,163,000</u>

We present pro forma R&D and pro forma SG&A expenses, which are non-GAAP measures, because we believe this presentation provides useful information on our aggregate R&D and SG&A spending.

Non-operating expenses/Interest income

Interest income decreased to \$4,451,000 in fiscal 2002 from \$12,555,000 in fiscal 2001. This decrease in interest income reflects the lower cash balances available for investment as a result of cash being used to fund our operations and to purchase property, plant and equipment, as well as lower interest rates available on our investments. Other income (expense), net of \$117,000 in fiscal 2002 consists primarily of investment gains from long-term marketable securities.

Liquidity and Capital Resources

On March 31, 2003, we had cash, cash equivalents and long-term marketable securities of \$20,049,000 compared to \$68,200,000 at March 31, 2002. In the fourth quarter of fiscal 2003, our cash equivalents balance declined by \$3,663,000 from \$23,712,000 as of December 31, 2002 to \$20,049,000 at March 31, 2003. The principal uses of cash during fiscal 2003 were \$39,605,000 for the funding of our operations (including \$11,011,000 to reduce our fiscal 2002 year-end accounts payable liabilities resulting from equipment purchases and restructuring and other charges incurred during the fourth quarter of fiscal 2002) and \$7,799,235 for the acquisition of property, plant and equipment, primarily for our HTS manufacturing facility in Devens, Massachusetts.

We have potential funding commitments (excluding amounts included in accounts receivable) of approximately \$78,336,000 to be received after March 31, 2003 from government and commercial customers, compared to \$11,020,000 at March 31, 2002. However, these current funding commitments, including \$70,006,000 on U.S. government contracts, are subject to certain standard cancellation provisions. Additionally, several of our government contracts are being funded incrementally, and as such, are subject to the future authorization and appropriation of government funding on an annual basis. We have a history of successful performance under incrementally-funded contracts with the U. S. government.

AMERICAN SUPERCONDUCTOR CORPORATION
MANAGEMENT'S DISCUSSION AND ANALYSIS OF FINANCIAL
CONDITION AND RESULTS OF OPERATIONS—(Continued)

Included in our current potential funding commitment amount is \$65,426,000 relating to the Navy 36.5 MW motor contract, which represents the total base program value (excluding certain potential performance-based incentive fees) of \$66,611,000, less the \$1,185,000 of revenue recognized in March 2003. In the first month (March 2003) of this three-year contract, we received two follow-on contract modifications allotting a cumulative total of \$14,348,000 of funding to the contract, out of the \$66,611,000 total contract value. We expect to continue to receive additional contract modifications in fiscal 2004 and beyond as incremental funding is authorized by the Navy.

Of the current commitment amount of \$78,336,000 as of March 31, 2003, approximately 42% is billable to and potentially collectable from our customers within the next 12 months.

The possibility exists that we may pursue acquisition and joint venture opportunities in the future that may affect liquidity and capital resource requirements.

To date, inflation has not had a material impact on our financial results.

We have generated operating losses since our inception in 1987 and expect to continue incurring losses until at least the end of fiscal 2005. Operating losses for the fiscal years ended March 31, 2003, 2002 and 2001 have contributed to net cash used by operating activities of \$39.6 million, \$26.5 million and \$26.4 million, respectively, for these periods. This three-year history of operating cash usage is on average greater than our balance of cash, cash equivalents and long-term marketable securities at March 31, 2003 of \$20.0 million. Furthermore, we anticipate that operating losses in the first quarter of fiscal 2004 ending June 30, 2003 will cause our balance of cash, cash equivalents and long-term marketable securities to decrease to between \$11 million and \$13 million.

To respond to the cash usage projected in the first fiscal quarter, we will be undertaking a series of cost reduction actions beginning in the second fiscal quarter. Some or all of these actions will encompass curtailing or discontinuing selected outside services, freezing new hiring and headcount attrition. In addition, we plan to defer all but the most essential capital expenditures for the remainder of the year. We estimate that cash savings generated from these actions should amount to approximately \$4 million in fiscal 2004.

The cash savings from the aforementioned cost reduction actions combined with an increasing level of revenues for the remainder of the fiscal year are expected to lower our quarterly cash usage beginning in the second quarter of fiscal 2004. The revenue increase is supported by our receipt in March 2003 of the three-year 36.5 MW motor contract from the Office of Naval Research as well as our selection in April 2003 by the Department of Energy (DOE) as the prime contractor for an HTS cable project.

During the first quarter of fiscal 2004, we experienced a slower than planned ramp-up of the 36.5 MW Navy motor program and the DOE cable project, and lower than anticipated orders from our Power Electronics Systems business unit. We believe that the Navy and DOE programs are currently on track to meet our full-year revenue targets in support of our overall \$45-50 million revenue target for fiscal 2004.

To supplement our anticipated cash needs from operations as well as to fund our investment in the second generation wire development program, we have been examining a number of options for raising additional capital. Based on these efforts over the last year, we signed in June 2003 non-binding letters of intent with three groups of investors to provide up to \$50 million in financing. These letters of intent are subject to satisfactory due diligence by these investors, the completion of formal legal documentation and approval of the financings by

AMERICAN SUPERCONDUCTOR CORPORATION
MANAGEMENT'S DISCUSSION AND ANALYSIS OF FINANCIAL
CONDITION AND RESULTS OF OPERATIONS—(Continued)

our shareholders. The \$50 million financing is expected to be comprised of a five-year term loan of up to \$30 million to be provided by a corporate finance company and several institutional investors with these amounts secured by our existing assets and additional assets projected to be acquired, excluding accounts receivable and inventory. In addition, three institutional investors have also signed a non-binding letter of intent to provide \$10 million in the form of subordinated notes that are convertible into our common stock. We have also signed a non-binding letter of intent with a commercial bank to provide up to \$10 million in the form of a working capital credit facility that is to be secured by our accounts receivable and inventory.

Each of the investor groups will also be issued warrants to acquire shares of our common stock. The conversion feature of the subordinated convertible notes combined with the warrants will trigger the NASDAQ requirement that our shareholders approve this \$50 million financing transaction prior to its closing. Consequently, should we be able to close this transaction, the earliest this would occur would be the end of August 2003. We expect that all of the contemplated financings will be required to close simultaneously. While we believe we will be able to complete the \$50 million financing transaction, we can make no assurance that such funds will be available, or available under terms acceptable to us, or that our shareholders will approve this financing transaction. In the event that this transaction cannot be completed, we are confident that we could obtain conventional mortgage financing on our Devens, MA manufacturing facility that, combined with our available cash, cash equivalents and long-term marketable securities, would be sufficient to satisfy our anticipated cash requirements for our fiscal year ending March 31, 2004.

Contractual Obligations

As of March 31, 2003, we had committed to make the following payments under contractual obligations using cash:

<u>Contractual obligations</u>	<u>Payments due by period</u>				
	<u>Total</u>	<u>Less than 1 year</u>	<u>1-3 years</u>	<u>4-5 years</u>	<u>After 5 years</u>
Operating leases	\$ 18,446,000	\$ 2,855,000	\$ 5,608,000	\$ 5,405,000	\$ 4,578,000
Unconditional purchase obligations (subcontracts)	1,022,000	1,022,000	—	—	—
Total contractual cash obligations	\$ 19,468,000	\$ 3,877,000	\$ 5,608,000	\$ 5,405,000	\$ 4,578,000

New Accounting Pronouncements

In June 2002, the Financial Accounting Standards Board (FASB) issued SFAS No. 146, "Accounting for Costs Associated with Exit or Disposal Activities". This statement addresses financial accounting and reporting for costs associated with exit or disposal activities and nullifies EITF Issue No. 94-3, "Liability Recognition for Certain Employee Termination Benefits and Other Costs to Exit an Activity (including Certain Costs Incurred in a Restructuring)" ("EITF 94-3"). SFAS No. 146 requires that a liability for a cost associated with an exit or disposal activity be recognized when the liability is incurred. EITF 94-3 allowed for an exit cost liability to be recognized at the date of an entity's commitment to an exit plan. SFAS 146 also requires that liabilities recorded in connection with exit plans be initially measured at fair value. The provisions of SFAS 146 are effective for exit or disposal activities that are initiated after December 31, 2002, with early adoption encouraged. We do not expect the adoption of SFAS 146 to have a material impact on our financial position or results of operations.

AMERICAN SUPERCONDUCTOR CORPORATION
MANAGEMENT’S DISCUSSION AND ANALYSIS OF FINANCIAL
CONDITION AND RESULTS OF OPERATIONS—(Continued)

In November 2002, the FASB issued FASB Interpretation No. 45 (FIN 45) “Guarantor’s Accounting and Disclosure Requirements for Guarantees, including Indirect Guarantees of Indebtedness of Others—an interpretation of FASB Statements No. 5, 57 and 107 and rescission of FASB Interpretation No. 34.” FIN 45 clarifies that a guarantor is required to recognize, at the inception of the guarantee, a liability for the fair value of the obligation undertaken in issuing certain guarantees. FIN 45 also requires additional disclosures to be made by a guarantor in its interim and annual financial statements about its obligations under certain guarantees it has issued. The accounting requirements for the initial recognition of guarantees are applicable on a prospective basis for guarantees issued or modified after December 31, 2002. The disclosure requirements are effective for all guarantees outstanding, regardless of when they were issued or modified, beginning with periods ending after December 15, 2002. We have applied the disclosure provisions of FIN 45 as of December 31, 2002, as required. The adoption of FIN 45 did not have a material effect on our consolidation financial statements for the year end March 31, 2003.

On December 31, 2002, the FASB issued SFAS No. 148, “Accounting for Stock-Based Compensation—Transition and Disclosure”. SFAS 148 amends SFAS 123, “Accounting for Stock-Based Compensation”, to provide alternative methods of transition for a voluntary change to the fair value based method of accounting for stock-based employee compensation. In addition, SFAS 148 amends the disclosure requirements of SFAS 123 to require prominent disclosures in both annual and interim financial statements about the method of accounting for stock-based employee compensation and the effect of the method used on reported results. The transition and annual disclosure provisions are effective for fiscal years ending after December 15, 2002. The new interim disclosure provisions are effective for the first interim period beginning after December 15, 2002. We have complied with the disclosure requirements of SFAS 148.

In January 2003, the FASB issued FASB Interpretation No. 46 (FIN 46), “Consolidation of Variable Interest Entities.” In general, a variable interest entity is a corporation, partnership, trust or any other legal structure used for business purposes that either (a) does not have equity investors with voting rights or (b) has equity investors that do not provide sufficient financial resources for the entity to support its activities. A variable interest entity often holds financial assets, including loans or receivables, real estate or other property. Variable interest entities have been commonly referred to as special-purpose entities or off-balance sheet structures. This Interpretation requires a variable interest entity to be consolidated by a company if that company is subject to a majority of the risk of loss from the variable interest entity’s activities or entitled to receive a majority of the entity’s residual returns or both. We do not expect that this Interpretation will have a material impact on our financial position or results of operations.

FUTURE OPERATING RESULTS

Various statements included herein, as well as other statements made from time to time by our representatives, which relate to future matters (including but not limited to statements concerning our future commercial success) constitute forward looking statements and are made under the “safe harbor” provisions of the Private Securities Litigation Reform Act of 1995. There are a number of important factors which could cause our actual results of operations and financial condition in the future to vary from that indicated in such forward looking statements. Factors that may cause such differences include, without limitation, the risks, uncertainties and other information set forth below.

We have a history of operating losses and we expect to continue to incur losses in the future.

We have been principally engaged in research and development activities. We have incurred net losses in each year since our inception. Our net loss for fiscal 2003, fiscal 2002, and fiscal 2001 was \$87,633,000, \$56,985,000, and \$21,676,000, respectively. Our accumulated deficit as of March 31, 2003 was \$273,110,000.

AMERICAN SUPERCONDUCTOR CORPORATION
MANAGEMENT'S DISCUSSION AND ANALYSIS OF FINANCIAL
CONDITION AND RESULTS OF OPERATIONS—(Continued)

We expect to continue to incur operating losses until the end of fiscal 2005 and there can be no assurance that we will ever achieve profitability.

We believe, based upon our current business plan, that our existing capital resources will be sufficient to fund our operations until the end of fiscal 2004. However, recognizing that we may need additional funds sooner than anticipated to fund current operations and to accelerate our investment in our second generation wire development program, we are currently examining options for raising additional capital to strengthen our cash position. There can be no assurance that such funds, whether from equity or debt financing, development contracts or other sources, will be available, or available under terms acceptable to us. Please see the discussion under "Liquidity and Capital Resources" above.

There are a number of technological challenges that must be successfully addressed before our superconductor products can gain widespread commercial acceptance.

Many of our products are in the early stages of commercialization and testing, while others are still under development. We do not believe any company has yet successfully developed and commercialized significant quantities of HTS wire or wire products. There are a number of technological challenges that we must successfully address to complete our development and commercialization efforts. We also believe that several years of further development in the cable and motor industries will be necessary before a substantial number of additional commercial applications for our HTS wire in these industries can be developed and proven. We may also need to improve the performance and/or reduce the cost of our HTS wire to expand the number of commercial applications for it. We may be unable to meet such technological challenges. Delays in development, as a result of technological challenges or other factors, may result in the introduction or commercial acceptance of our products later than anticipated.

The commercial uses of superconductor products are very limited today, and a widespread commercial market for our products may not develop.

To date, there has been no widespread commercial use of HTS products. Commercial acceptance of low temperature superconductor (LTS) products, other than for medical magnetic resonance imaging and superconductor magnetic energy storage products, has been significantly limited by the cooling requirements of LTS materials. Even if the technological hurdles currently limiting commercial uses of HTS and LTS products are overcome, it is uncertain whether a robust commercial market for those new and unproven products will ever develop. It is possible that the market demands we currently anticipate for our HTS and LTS products will not develop and that superconductor products will never achieve widespread commercial acceptance.

We have limited experience manufacturing our HTS products in commercial quantities.

To be financially successful, we will have to manufacture our products in commercial quantities at acceptable costs while also preserving the quality levels we have achieved in manufacturing these products in limited quantities. This presents a number of technological and engineering challenges for us. We cannot make assurances that we will be successful in developing product designs and manufacturing processes that permit us to manufacture our HTS products in commercial quantities at commercially acceptable costs while preserving quality. In addition, we may incur significant unforeseen expenses in our product design and manufacturing efforts.

AMERICAN SUPERCONDUCTOR CORPORATION
MANAGEMENT'S DISCUSSION AND ANALYSIS OF FINANCIAL
CONDITION AND RESULTS OF OPERATIONS—(Continued)

We have historically focused on research and development activities and have limited experience in marketing and selling our products.

We have been primarily focused on research and development of our superconductor products. Consequently, our management team has limited experience directing our commercialization efforts, which are essential to our future success. To date, we have only limited experience marketing and selling our products, and there are very few people anywhere who have significant experience marketing or selling superconductor products. Once our products are ready for commercial use, we will have to develop a marketing and sales organization that will effectively demonstrate the advantages of our products over both more traditional products and competing superconductor products or other technologies. We may not be successful in our efforts to market this new and unfamiliar technology, and we may not be able to establish an effective sales and distribution organization.

We may decide to enter into arrangements with third parties for the marketing or distribution of our products, including arrangements in which our products, such as HTS wire, are included as a component of a larger product, such as a motor. For example, we have a marketing and sales alliance with GE Industrial Systems giving GE the exclusive right to offer our Distributed-SMES (D-SMES) and D-VAR™ product lines in the United States to utilities and the right to sell industrial Power Quality-Industrial Voltage Restorers (PQ-IVR™) to certain of GE's global industrial accounts. We also have a distribution agreement with Bridex Technologies Pte, Ltd., a power system solution integrator and technology company in Singapore, whereby Bridex markets and sells our integrated power electronic systems within Asia Pacific markets. By entering into marketing and sales alliances, the financial benefits to us of commercializing our products are dependent on the efforts of others. We may not be able to enter into marketing or distribution arrangements with third parties on financially acceptable terms, and third parties may not be successful in selling our products or applications incorporating our products.

Our products face intense competition both from superconductor products developed by others and from traditional, non-superconductor products and alternative technologies.

As we begin to market and sell our superconductor products, we will face intense competition both from competitors in the superconductor field and from vendors of traditional products and new technologies. There are many companies in the United States, Europe, Japan and China engaged in the development of HTS products, including Sumitomo Electric Industries, Intermagnetics General, Vacuumschmelze, Fujikura, Furukawa Electric, and Innova. The superconductor industry is characterized by rapidly changing and advancing technology. Our future success will depend in large part upon our ability to keep pace with advancing HTS and LTS technology and developing industry standards. Our SMES products and integrated power electronic products, such as D-VAR™, compete with a variety of other products such as dynamic voltage restorers ("DVRs"), static VAR compensators ("SVCs"), static compensators ("STATCOMS"), flywheels, power electronic converters and battery-based power supply systems. Competition for our PowerModules™ includes products from Ecostar, Inverpower, Satcon, Semikron and Trace. The HTS motor and generator products that we are developing face competition from copper wire-based motors and generators, and from permanent magnet motors that are being developed. Research efforts and technological advances made by others in the superconductor field or in other areas with applications to the power quality and reliability markets may render our development efforts obsolete. Many of our competitors have substantially greater financial resources, research and development, manufacturing and marketing capabilities than we have. In addition, as the HTS wire, HTS electric motors and generators, and power electronic systems markets develop, other large industrial companies may enter those fields and compete with us.

AMERICAN SUPERCONDUCTOR CORPORATION
MANAGEMENT'S DISCUSSION AND ANALYSIS OF FINANCIAL
CONDITION AND RESULTS OF OPERATIONS—(Continued)

Third parties have or may acquire patents that cover the high temperature superconductor materials we use or may use in the future to manufacture our products.

We expect that some or all of the HTS materials and technologies we use in designing and manufacturing our products are or will become covered by patents issued to other parties, including our competitors. If that is the case, we will need either to acquire licenses to these patents or to successfully contest the validity of these patents. The owners of these patents may refuse to grant licenses to us, or may be willing to do so only on terms that we find commercially unreasonable. If we are unable to obtain these licenses, we may have to contest the validity or scope of those patents to avoid infringement claims by the owners of these patents. It is possible that we will not be successful in contesting the validity or scope of a patent, or that we will not prevail in a patent infringement claim brought against us. Even if we are successful in such a proceeding, we could incur substantial costs and diversion of management resources in prosecuting or defending such a proceeding.

There are numerous patents issued in the field of superconductor materials and our patents may not provide meaningful protection for our technology.

We own or have licensing rights under many patents and pending patent applications. However, the patents that we own or license may not provide us with meaningful protection of our technologies, and may not prevent our competitors from using similar technologies, for a variety of reasons, such as:

- the patent applications that we or our licensors file may not result in patents being issued;
- any patents issued may be challenged by third parties; and
- others may independently develop similar technologies not protected by our patents or design around the patented aspects of any technologies we develop.

Moreover, we could incur substantial litigation costs in defending the validity of our own patents. We also rely on trade secrets and proprietary know-how to protect our intellectual property. However, our non-disclosure agreements and other safeguards may not provide meaningful protection for our trade secrets and other proprietary information.

Our success is dependent upon attracting and retaining qualified personnel.

Our success will depend in large part upon our ability to attract and retain highly qualified research and development, management, manufacturing, marketing and sales personnel. Hiring those persons may be especially difficult due to the specialized nature of our business.

We are particularly dependent upon the services of Dr. Gregory J. Yurek, our co-founder and our Chairman of the Board, President and Chief Executive Officer, and Dr. Alexis P. Malozemoff, our Chief Technical Officer. The loss of the services of either of those individuals could significantly damage our business and prospects.

REPORT OF INDEPENDENT ACCOUNTANTS

To the Board of Directors and Stockholders of
American Superconductor Corporation:

In our opinion, the accompanying consolidated balance sheets and the related consolidated statements of operations, comprehensive loss, stockholders' equity and cash flows present fairly, in all material respects, the financial position of American Superconductor Corporation and its subsidiaries at March 31, 2003 and 2002, and the results of their operations and their cash flows for each of the three years in the period ended March 31, 2003 in conformity with accounting principles generally accepted in the United States of America. These financial statements are the responsibility of the Company's management; our responsibility is to express an opinion on these financial statements based on our audits. We conducted our audits of these statements in accordance with auditing standards generally accepted in the United States of America, which require that we plan and perform the audit to obtain reasonable assurance about whether the financial statements are free of material misstatement. An audit includes examining, on a test basis, evidence supporting the amounts and disclosures in the financial statements, assessing the accounting principles used and significant estimates made by management, and evaluating the overall financial statement presentation. We believe that our audits provide a reasonable basis for our opinion.



Boston, Massachusetts
June 27, 2003

AMERICAN SUPERCONDUCTOR CORPORATION
CONSOLIDATED BALANCE SHEETS

	March 31,	
	2003	2002
ASSETS		
Current assets:		
Cash and cash equivalents	\$ 18,487,752	\$ 37,170,927
Accounts receivable	5,446,007	7,583,505
Inventory	5,117,786	13,212,831
Prepaid expenses and other current assets	1,264,839	708,079
Total current assets	30,316,384	58,675,342
Property and equipment:		
Land	4,021,611	4,244,611
Construction in progress—building and equipment	8,773,458	79,685,813
Building	34,102,138	—
Equipment	31,966,730	24,939,124
Furniture and fixtures	4,167,345	3,833,016
Leasehold improvements	6,246,497	6,226,267
	89,277,779	118,928,831
Less: accumulated depreciation	(28,241,982)	(21,209,230)
Property and equipment, net	61,035,797	97,719,601
Long-term marketable securities	1,561,120	31,028,683
Long-term inventory	3,250,000	3,787,000
Goodwill	1,107,735	1,107,735
Other assets	4,707,603	5,476,563
Total assets	\$ 101,978,639	\$ 197,794,924
LIABILITIES AND STOCKHOLDERS' EQUITY		
Current liabilities:		
Accounts payable and accrued expenses	\$ 9,773,874	\$ 20,784,931
Deferred revenue	1,136,002	1,056,806
Total current liabilities	10,909,876	21,841,737
Long-term deferred revenue	3,250,000	3,787,000
Commitments (Note 11)		
Stockholders' equity:		
Common stock, \$.01 par value		
Authorized shares—50,000,000; issued and outstanding		
21,293,772 and 20,497,514 at March 31, 2003 and 2002, respectively	212,938	204,975
Additional paid-in capital	361,024,689	357,781,718
Deferred compensation	(311,563)	(318,199)
Deferred contract costs	—	(121,167)
Accumulated other comprehensive income	2,407	95,641
Accumulated deficit	(273,109,708)	(185,476,781)
Total stockholders' equity	87,818,763	172,166,187
Total liabilities and stockholders' equity	\$ 101,978,639	\$ 197,794,924

The accompanying notes are an integral part of the consolidated financial statements.

AMERICAN SUPERCONDUCTOR CORPORATION
CONSOLIDATED STATEMENTS OF OPERATIONS

	Year ended March 31,		
	2003	2002	2001
Revenues:			
Contract revenue	\$ 715,109	\$ 2,111,460	\$ 3,185,537
Product sales and prototype development contracts	20,305,183	9,538,640	13,581,987
Total revenues	21,020,292	11,650,100	16,767,524
Costs and expenses:			
Costs of revenue—contract revenue	684,341	2,100,789	3,135,440
Costs of revenue—product sales and prototype development contracts	31,517,605	17,298,856	10,980,753
Research and development	21,940,369	27,814,044	22,832,357
Selling, general and administrative	16,158,585	16,313,306	14,214,542
Pirelli license costs	—	4,009,890	—
Restructuring charges	—	5,666,059	—
Impairment charge	39,230,877	—	—
Total costs and expenses	109,531,777	73,202,944	51,163,092
Operating loss	(88,511,485)	(61,552,844)	(34,395,568)
Interest income	868,648	4,450,769	12,555,411
Other income, net	9,910	117,186	164,146
Net loss	\$ (87,632,927)	\$ (56,984,889)	\$ (21,676,011)
Net loss per common share			
Basic and diluted	\$ (4.21)	\$ (2.79)	\$ (1.08)
Weighted average number of common shares outstanding			
Basic and diluted	20,830,846	20,409,233	20,127,348

The accompanying notes are an integral part of the consolidated financial statements.

AMERICAN SUPERCONDUCTOR CORPORATION
CONSOLIDATED STATEMENTS OF CASH FLOWS

	Year ended March 31,		
	2003	2002	2001
Cash flows from operating activities:			
Net loss	\$ (87,632,927)	\$ (56,984,889)	\$ (21,676,011)
Adjustments to reconcile net loss to net cash used by operations:			
Depreciation and amortization	8,102,136	5,509,043	4,098,904
Impairment charge	39,230,877	—	—
Allowance for doubtful accounts	2,624,010	727,028	—
Inventory write-down charges	3,421,100	3,464,275	—
Loss on disposal of PP&E, patents, and licenses	875,123	—	—
Restructuring charges (non-cash portion)	—	2,929,741	—
Pirelli license payment (non-cash portion)	—	1,720,500	—
Deferred compensation expense	14,777	106,067	106,067
Deferred warrant costs	174,457	268,470	354,495
Stock compensation expense	367,192	479,472	222,014
Changes in operating asset and liability accounts :			
Accounts receivable	(486,512)	4,947,670	(5,546,781)
Inventory	5,360,285	(2,376,178)	(8,580,998)
Prepaid expenses and other current assets	(532,114)	(167,801)	205,385
Accounts payable and accrued expenses	(10,665,557)	11,863,409	2,236,999
Deferred revenue—current and long-term	(457,804)	1,056,806	2,155,867
Net cash used by operating activities	(39,604,957)	(26,456,387)	(26,424,059)
Cash flows from investing activities:			
Purchase of property and equipment	(7,799,235)	(63,122,176)	(35,897,926)
Purchase of long-term marketable securities	(770,000)	—	—
Sale of long-term marketable securities	30,119,683	39,452,114	21,526,392
Purchase of assets of Integrated Electronics, LLC	—	—	(755,000)
Net investment in sales-type lease	—	—	279,110
Increase in other assets	(992,457)	(3,173,100)	(2,175,930)
Net cash provided by/(used in) investing activities	20,557,991	(26,843,162)	(17,023,354)
Cash flows from financing activities:			
Net proceeds from issuance of common stock	363,791	1,407,177	5,592,944
Net cash provided by financing activities	363,791	1,407,177	5,592,944
Net increase (decrease) in cash and cash equivalents	(18,683,175)	(51,892,372)	(37,854,469)
Cash and cash equivalents at beginning of year	37,170,927	89,063,299	126,917,768
Cash and cash equivalents at end of year	\$ 18,487,752	\$ 37,170,927	\$ 89,063,299
Supplemental schedule of cash flow information:			
Noncash issuance of common stock	\$ 727,469	\$ 585,539	\$ 1,406,206
Noncash purchase of NST Inventory	\$ 149,340	\$ —	\$ —
Noncash purchase of NST Property, Plant & Equipment	1,763,680	—	—
Noncash purchase of NST Patent assets	200,000	—	—
Noncash issuance of common stock—NKT Holding	\$ 2,113,020	\$ —	\$ —

The accompanying notes are an integral part of the consolidated financial statements.

AMERICAN SUPERCONDUCTOR CORPORATION
CONSOLIDATED STATEMENTS OF COMPREHENSIVE LOSS

	Year ended March 31,		
	2003	2002	2001
Net loss	\$ (87,632,927)	\$ (56,984,889)	\$ (21,676,011)
Other comprehensive (loss)			
Foreign currency translation	24,646	7,007	(8,591)
Unrealized gains (losses) on investments	(117,880)	(681,007)	950,747
Other comprehensive income (loss)	(93,234)	(674,000)	942,156
Comprehensive income (loss)	\$ (87,726,161)	\$ (57,658,889)	\$ (20,733,855)

The accompanying notes are an integral part of the consolidated financial statements.

AMERICAN SUPERCONDUCTOR CORPORATION
CONSOLIDATED STATEMENTS OF STOCKHOLDERS' EQUITY

	Common Stock		Additional Paid-in Capital	Deferred Compensation	Deferred Contract Costs	Other Comprehensive Income (Loss)	Accumulated Deficit	Total Stockholders' Equity
	Number of Shares	Par Value						
Balance at March 31, 2000	19,734,714	197,347	348,903,034	(530,333)	(637,552)	(172,515)	(106,815,881)	240,944,100
Exercise of stock options	490,068	4,901	5,572,335					5,577,236
Purchase of IE	37,500	375	1,077,750					1,078,125
Exercise of stock warrants	18,253	182	15,526					15,708
Amortization of deferred compensation				106,067				106,067
Stock compensation expense	10,061	101	221,913					222,014
Amortization of deferred warrant costs			53,290		301,205			354,495
Unrealized gain on investments						950,747		950,747
Cumulative translation adjustment						(8,591)		(8,591)
Net loss							(21,676,011)	(21,676,011)
Balance at March 31, 2001	20,290,596	\$ 202,906	\$ 355,843,848	\$ (424,266)	\$ (336,347)	\$ 769,641	\$ (128,491,892)	\$ 227,563,890
Exercise of stock options	75,166	752	708,748					709,500
Issuance of common stock—ESPP	96,720	967	696,710					697,677
Amortization of deferred compensation				106,067				106,067
Stock compensation expense	35,032	350	479,122					479,472
Amortization of deferred warrant costs			53,290		215,180			268,470
Unrealized loss on investments						(681,007)		(681,007)
Cumulative translation adjustment						7,007		7,007
Net loss							(56,984,889)	(56,984,889)
Balance at March 31, 2002	20,497,514	\$ 204,975	\$ 357,781,718	\$ (318,199)	\$ (121,167)	\$ 95,641	\$ (185,476,781)	\$ 172,166,187
Issuance of common stock—ESPP	88,881	889	362,902					363,791
Purchase of NST Assets	546,000	5,460	2,107,560					2,113,020
Issuance of common stock to Pirelli	50,000	500	345,000					345,500
Deferred Compensation	30,000	300	7,841	(8,141)				0
Amortization of deferred compensation				14,777				14,777
Stock compensation expense	81,377	814	366,378					367,192
Amortization of deferred warrant costs			53,290		121,167			174,457
Unrealized loss on investments						(117,880)		(117,880)
Cumulative translation adjustment						24,646		24,646
Net loss							(87,632,927)	(87,632,927)
Balance at March 31, 2003	21,293,772	\$ 212,938	\$ 361,024,689	\$ (311,563)	\$ —	\$ 2,407	\$ (273,109,708)	\$ 87,818,763

The accompanying notes are an integral part of the consolidated financial statements.

AMERICAN SUPERCONDUCTOR CORPORATION
NOTES TO CONSOLIDATED STATEMENTS

1. Nature of the Business and Operations

American Superconductor Corporation (the "Company"), which was formed on April 9, 1987, is a world leader in developing and manufacturing products using superconducting materials and power electronic converters for electric power applications. The focus of the Company's development and commercialization efforts is on electrical equipment for electric utilities, transmission grid operators, industrial and commercial users of electrical power, and commercial and military ships. For large-scale applications, the Company's development efforts are focused on high temperature superconductor ("HTS") wire for use in power transmission cables, motors, and generators. The Company is also developing and commercializing electric motors and generators based on its HTS wire. For power quality and reliability applications, the Company is focused on proprietary power electronic converters that rapidly switch, control and modulate power. The Company also designs, manufactures, and sells systems based on those power electronic converters for power quality and reliability solutions. The Company operates in three business segments—AMSC Wires, SuperMachines and Power Electronic Systems.

The Company has generated operating losses since its inception in 1987 and expects to continue incurring losses until at least the end of fiscal 2005. Operating losses for the fiscal years ended March 31, 2003, 2002 and 2001 have contributed to net cash used by operating activities of \$39.6 million, \$26.5 million and \$26.4 million, respectively, for these periods. This three-year history of operating cash usage is on average greater than the Company's balance of cash, cash equivalents and long-term marketable securities at March 31, 2003 of \$20.0 million. Furthermore, the Company anticipates that operating losses in the first quarter of fiscal 2004 ending June 30, 2003 will cause its balance of cash, cash equivalents and long-term marketable securities to decrease to between \$11 million and \$13 million.

To respond to the cash usage projected in the first fiscal quarter, the Company will be undertaking a series of cost reduction actions beginning in the second fiscal quarter. Some or all of these actions will encompass curtailing or discontinuing selected outside services, freezing new hiring, and headcount attrition. In addition, the Company plans to defer all but the most essential capital expenditures. The cash savings from the aforementioned cost reduction actions combined with an increasing level of revenues for the remainder of the fiscal year are expected to lower the Company's quarterly cash usage beginning in the second quarter of fiscal 2004.

To supplement the Company's anticipated cash needs from operations as well as to fund its investment in the second generation wire development program, the Company has been examining a number of options for raising additional capital. Based on these efforts over the last year, the Company, in June 2003, signed non-binding letters of intent with three groups of investors to provide up to \$50 million in financing. These letters of intent are subject to satisfactory due diligence by these investors, the completion of formal legal documentation and approval by the Company's shareholders. The \$50 million in financing is expected to be comprised of a five-year term loan of up to \$30 million to be provided by a corporate finance company and several institutional investors with these amounts secured by the Company's existing assets and those assets projected to be acquired, excluding accounts receivable and inventory. In addition, three institutional investors have also signed a non-binding letter of intent to provide \$10 million in the form of subordinated notes that are convertible into common stock of the Company. The Company has also signed a non-binding letter of intent with a commercial bank to provide up to \$10 million in the form of a working capital credit facility that is to be secured by the Company's accounts receivable and inventory.

Each of the investor groups will also be issued warrants to acquire shares of the Company's common stock. The conversion feature of the subordinated convertible notes combined with the warrants will trigger the NASDAQ requirement that the Company's shareholders approve this \$50 million financing transaction prior to its closing. Consequently, should the Company be able to close this transaction, the earliest this would occur

AMERICAN SUPERCONDUCTOR CORPORATION
NOTES TO CONSOLIDATED STATEMENTS—(Continued)

would be the end of August 2003. While the Company believes it will be able to complete the \$50 million financing transaction, it can make no assurance that such funds will be available, or available under terms acceptable to it, or that the Company's shareholders will approve this financing transaction. In the event that this transaction cannot be completed, the Company is confident that it could obtain conventional mortgage financing on its Devens, MA manufacturing facility that, combined with its available cash, cash equivalents and long-term marketable securities, would be sufficient to satisfy the Company's anticipated cash requirements for its fiscal year ending March 31, 2004.

The Company currently derives a portion of its revenue from research and development contracts. The Company recorded contract revenue related to research and development contracts of \$715,109, \$2,111,460, and \$3,185,537 for the fiscal years ended March 31, 2003, 2002, and 2001, respectively. In addition, the Company recorded prototype development contract revenues on U.S. Navy contracts of \$8,220,348, \$6,036,591, and \$2,507,399, which are included under "Revenues—Product sales and prototype development contracts", for the fiscal years ended March 31, 2003, 2002, and 2001, respectively.

Costs of revenue include research and development and selling, general and administrative expenses that are incurred in the performance of these development contracts.

Research and development and Selling, general and administrative expenses included as Costs of revenue were as follows:

	For the years ended March 31,		
	2003	2002	2001
Research and development expenses	\$ 10,997,000	\$ 8,757,000	\$ 5,879,000
Selling, general and administrative expenses	\$ 1,482,000	\$ 1,659,000	\$ 1,821,000

2. Summary of Significant Accounting Policies

A summary of the Company's significant accounting policies follows:

The consolidated financial statements include the accounts of the Company and its wholly-owned subsidiaries. All significant intercompany balances are eliminated. Certain prior year amounts have been reclassified to be consistent with the current year presentation.

Cash Equivalents

The Company considers all highly liquid debt instruments with original maturities of three months or less to be cash equivalents. Cash equivalents consist of government obligations, repurchase agreements, money market accounts, and other debt instruments.

Accounts Receivable

Due to scheduled billing requirements specified under certain contracts, a portion of the Company's accounts receivable balance at March 31, 2003 and 2002 was unbilled. The Company expects most of the unbilled balance at March 31, 2003 to be billed by the first quarter of the fiscal year ending March 31, 2004. At March 31, 2003, the Company had three customers that represented approximately 48%, 15% and 10% of the total accounts receivable balance. At March 31, 2002, the Company had two customers that represented approximately 43% and 38% of the total accounts receivable balance.

AMERICAN SUPERCONDUCTOR CORPORATION
NOTES TO CONSOLIDATED STATEMENTS—(Continued)

Long-term Marketable Securities

Long-term marketable securities, with original maturities of 12 months or more when purchased, consist primarily of U.S. Treasury Notes, U.S. government agency securities, corporate bonds and other debt securities, in accordance with Statement of Financial Accounting Standards (“SFAS”) No. 115, “Accounting for Certain Investments in Debt and Equity Securities.” The Company determines the appropriate classification of its marketable securities at the time of purchase and re-evaluates such classification as of each balance sheet date.

Inventories

Inventories are stated at the lower of cost (determined on a first-in first-out basis) or market.

Property and Equipment

The Company accounts for depreciation and amortization using the straight-line method to allocate the cost of property and equipment over their estimated useful lives as follows:

<u>Asset classification</u>	<u>Estimated useful life</u>
Building	40 years
Process upgrades to the building	10-40 years
Machinery and equipment	5-10 years
Furniture and fixtures	3 years
Leasehold improvements	Remaining lease term

Expenditures for maintenance and repairs are expensed as incurred. Upon retirement or other disposition of assets, the costs and related accumulated depreciation are eliminated from the accounts and the resulting gain or loss is reflected in income.

Depreciation expense was \$7,098,641, \$4,888,353, and \$3,768,518 for the fiscal years ended March 31, 2003, 2002, and 2001, respectively.

Acquisition of Assets

On October 31, 2002, the Company acquired fixed assets, inventory and patents from Nordic Superconductor Technologies A/S (NST), a subsidiary of NKT Holding A/S, in exchange for 546,000 shares of the Company’s common stock valued at \$2,113,020. NKT Holding has agreed to hold these shares for at least two years. NST had developed and marketed HTS wire to customers in Europe, Asia, and North America. The Company did not assume any debt or other liabilities in the transaction. No NST employees were retained by the Company. The assets acquired were fixed assets valued at \$1,763,680, patents valued at \$200,000, and inventory valued at \$149,340.

Goodwill and Other Intangible Assets

The Company has intangibles assets consisting of goodwill, licenses and patents.

Effective April 1, 2001, the Company adopted the provisions of Statement of Financial Accounting Standards (“SFAS”) No. 142, “Goodwill and Other Intangible Assets,” which requires that ratable amortization of goodwill and certain intangibles be replaced with periodic tests of goodwill’s impairment and that other intangibles be amortized over their useful lives unless these lives are determined to be indefinite. SFAS No. 142

AMERICAN SUPERCONDUCTOR CORPORATION
NOTES TO CONSOLIDATED STATEMENTS—(Continued)

requires that goodwill be tested annually for impairment under a two-step process or whenever events or changes in circumstances suggest that the carrying value of an asset may not be recoverable. The Company amortizes licenses and patents using the straight-line method over a period up to 7 years.

The Company reviews its goodwill at least annually or when events or changes in circumstances indicate that the carrying amount of such assets may not be fully recoverable. If the carrying amount of the net tangible and intangible assets in a given reporting unit exceeds the reporting unit's fair value, a detailed impairment loss analysis would be performed to calculate the amount of impairment, if any, prescribed by Statement of Financial Accounting Standards ("SFAS") No. 142. Goodwill of \$1,107,735 at March 31, 2003 and 2002 represents the excess of the purchase price paid for the acquisition of substantially all of the assets of Integrated Electronics, LLC (IE) on June 1, 2000, over the fair value of IE's assets, less amortization. The IE transaction was accounted for under the purchase method of accounting. Goodwill was initially calculated to be \$1,329,282, and was amortized until the adoption of SFAS 142 on April 1, 2001.

Goodwill amortization expense was \$0 in the fiscal years ended March 31, 2003 and 2002, respectively, and \$221,547 in the fiscal year ended March 31, 2001. Accumulated goodwill amortization was \$221,547 at March 31, 2003 and 2002. Effective April 1, 2001, the Company adopted the provisions of SFAS No. 142, "Goodwill and Other Intangible Assets," and has ceased amortizing the goodwill recorded as a result of the acquisition of substantially all of the assets of IE on June 1, 2000.

The following table presents the impact SFAS No. 142 would have on the Company's net income had the standard been in effect for the year ended March 31, 2001. In fiscal 2001, the goodwill amortization was expensed through the Cost of revenue—product sales and prototype development contracts.

	Year ended March 31, 2001		
	As Reported	FAS 142 Adjustment	As Adjusted
Cost of revenue—product sales and prototype development contracts	(10,980,753)	221,547	(10,759,206)
Net loss	(21,676,011)	221,547	(21,454,464)
Net loss per common share—basic and diluted	(1.08)	.01	(1.07)

Accounting for Impairment of Long-Lived Assets

The Company periodically evaluates its long-lived assets for potential impairment under SFAS No. 144, "Accounting for the Impairment or Disposal of Long-Lived Assets." The Company performs these evaluations whenever events or circumstances suggest that the carrying amount of an asset or group of assets is not recoverable. The Company's judgments regarding the existence of impairment indicators are based on market and operational performance. Indicators of potential impairment include:

- a significant change in the manner in which an asset is used;
- a significant decrease in the market value of an asset;
- a significant adverse change in its business or the industry in which it is sold;
- a current period operating cash flow loss combined with a history of operating or cash flow losses or a projection or forecast that demonstrates continuing losses associated with the asset; and
- Significant advances in the Company's technologies that require changes in the manufacturing process.

AMERICAN SUPERCONDUCTOR CORPORATION
NOTES TO CONSOLIDATED STATEMENTS—(Continued)

If the Company believes an indicator of potential impairment exists, it tests to determine whether impairment recognition criteria in SFAS No. 144 have been met. To analyze a potential impairment, the Company projects undiscounted future cash flows over the remaining life of the asset or the primary asset in the asset group. If these projected cash flows are less than the carrying amount, an impairment loss is recognized based on the fair value of the asset or asset group less any costs of disposition. Evaluating the impairment requires judgment by the Company's management to estimate future operating results and cash flows. If different estimates were used, the amount and timing of asset impairments could be affected. The Company charges impairments of the long-lived assets to operations if its evaluations indicate that the carrying values of these assets are not recoverable.

Revenue Recognition

For certain arrangements, such as contracts to perform research and development and prototype development contracts, the Company records revenues using the percentage of completion method, measured by the relationship of costs incurred to total estimated contract costs. The Company follows this method since reasonably dependable estimates of the revenue and costs applicable to various stages of a contract can be made. Since many contracts extend over a long period of time, revisions in cost and funding estimates during the progress of work have the effect of adjusting earnings applicable to performance in prior periods in the current period. Recognized revenues and profit or loss are subject to revisions as the contract progresses to completion. Revisions in profit or loss estimates are charged to income in the period in which the facts that give rise to the revision become known.

The Company recognizes revenue from product sales upon shipment, installation or acceptance, where applicable, provided persuasive evidence of an arrangement exists, delivery has occurred, the sales price is fixed or determinable and collectibility is reasonably assured, or for some programs, on the percentage of completion method of accounting. When other significant obligations remain after products are delivered, revenue is recognized only after such obligations (including buyback provisions) are fulfilled.

Research and Development Costs

Research and development costs are expensed as incurred.

Income Taxes

Deferred income taxes are recognized for the tax consequences in future years of differences between the tax bases of assets and liabilities and their financial reporting amounts at each fiscal year end based on enacted tax laws and statutory tax rates applicable to the periods in which the differences are expected to affect taxable income. Valuation allowances are established when necessary to reduce net deferred tax assets to the amount expected to be realized. No current or deferred income taxes have been provided because of the net operating losses incurred by the Company since its inception.

Stock-Based Compensation Plans and Pro Forma Stock-Based Compensation Expense

The Company applies Accounting Principles Board Opinion ("APB") No. 25, "Accounting for Stock Issued to Employees," and related interpretations in accounting for its stock-based compensation plan. Accordingly, no accounting recognition is given to stock options granted at fair market value until they are exercised. Upon exercise, net proceeds, including tax benefits realized, are credited to stockholders' equity.

In October 1995, the FASB issued SFAS No. 123, "Accounting for Stock-Based Compensation," which sets forth a fair-value-based method of recognizing stock-based compensation expense. As permitted by SFAS No. 123, the Company has elected to continue to apply APB No. 25 to account for its stock-based compensation plan.

AMERICAN SUPERCONDUCTOR CORPORATION
NOTES TO CONSOLIDATED STATEMENTS—(Continued)

Had compensation cost for awards granted after 1994 under the Company's stock-based compensation plan been determined based on the fair value at the grant dates consistent with the method set forth under SFAS No. 123, the effect on certain financial information of the Company would have been as follows (in thousands):

	For the fiscal years ended March 31,		
	2003	2002	2001
Net loss (in thousands)	\$(87,633)	\$(56,985)	\$(21,676)
Add back restricted stock expense	14	106	106
Less: Stock compensation costs, net of tax, had all options been recorded at fair value per SFAS 123	(6,726)	(10,096)	(10,569)
Pro forma net loss	\$(94,345)	\$(66,975)	\$(32,139)
Weighted average shares, basic and diluted			
Net loss per share, as reported	\$ (4.21)	\$ (2.79)	\$ (1.08)
Net loss per share, pro forma	\$ (4.53)	\$ (3.28)	\$ (1.60)

The pro forma amounts include the effects of all activity under the Company's stock-based compensation plans since April 1, 1998. The fair value of each option grant is estimated on the date of grant using the Black-Scholes option pricing model with the following assumptions used for grants:

	2003	2002	2001
Dividend yield	None	None	None
Expected volatility	101%	87%	85%
Risk-free interest rate	4.0%	4.5%	5.7%
Expected life (years)	6.5	6.8	6.8
Weighted average fair value of options granted at fair market value during:			
2003			\$ 6.04
2002			\$ 10.35
2001			\$ 24.85

The above amounts may not be indicative of future expense because amounts are recognized over the vesting period and the Company expects it will have additional grants and related activity under these plans in the future.

Computation of Net Loss per Common Share

Basic earnings per share ("EPS") is computed by dividing net income available to common stockholders by the weighted-average number of common shares outstanding for the period. Diluted EPS is computed using the weighted average number of common and dilutive common equivalent shares outstanding during the period. Common equivalent shares include the effect of the exercise of stock options and warrants. For the years ended March 31, 2003, 2002, and 2001, common equivalent shares of 4,485,201, 2,537,279, and 2,523,769, respectively, were not included in the calculation of diluted EPS as they were considered antidilutive.

Foreign Currency Translation

The functional currency of the Company's foreign subsidiary is the local currency. The assets and liabilities of this operation are translated into U.S. dollars at the exchange rate in effect at the balance sheet date and

AMERICAN SUPERCONDUCTOR CORPORATION
NOTES TO CONSOLIDATED STATEMENTS—(Continued)

income and expense items are translated at average rates for the period. Cumulative translation adjustments are excluded from net loss and shown as a separate component of stockholders' equity. Foreign currency transaction gains and losses are included in the net loss and have not been material to date.

Risks and Uncertainties

The preparation of financial statements in conformity with generally accepted accounting principles requires management to make estimates and assumptions that affect the reported amounts of assets and liabilities and disclosures of contingent assets and liabilities at the date of the financial statements and the reported amounts of revenues and expenses during the reporting period. Actual results could differ from those estimates and would impact future results of operations and cash flows.

The Company invests its cash and cash equivalents with high-credit, quality financial institutions and invests primarily in investment grade-marketable securities, including, but not limited to, government obligations, repurchase agreements, and money market funds.

The Company's accounts receivable are comprised of amounts owed by government agencies and commercial companies. The Company does not require collateral or other security to support customer receivables.

Several of the Company's government contracts are being funded on an incrementally-funded basis, and as such, are subject to the future availability and authorizations of government funding. The Company has a history of successful performance under incrementally-funded contracts with the U.S. government and it expects to continue to receive additional contract modifications in fiscal 2004 and beyond as incremental funding is authorized and appropriated by the government.

3. Long-term Marketable Securities

Long-term marketable securities at March 31, 2003 and 2002 consisted of U.S. government and government agency securities and corporate bonds.

	2003	2002
Aggregate cost	\$ 1,552,249	\$ 30,909,413
Fair value	1,561,120	31,028,683
Gross unrealized gain	\$ 8,871	\$ 119,270

The Company's long-term marketable securities are classified as available-for-sale securities and, accordingly, are recorded at amortized cost plus accrued interest which approximates fair value. The difference between cost and fair value is included in stockholders' equity. All of these securities mature in one to two years.

4. Accounts Receivable

Accounts receivable at March 31, 2003 and 2002 consisted of the following:

	2003	2002
Accounts receivable (billed)	\$ 4,828,214	\$3,076,361
Accounts receivable (unbilled)	3,275,278	4,549,144
Less: Allowance for doubtful accounts	(2,657,485)	(42,000)
Net accounts receivable	\$ 5,446,007	\$7,583,505

AMERICAN SUPERCONDUCTOR CORPORATION
NOTES TO CONSOLIDATED STATEMENTS—(Continued)

The Company recorded a \$2,624,010 and \$727,028 allowance for doubtful accounts provision in fiscal 2003 and 2002, respectively. These are shown as part of selling, general and administrative expense. The \$727,028 receivable was written off in fiscal 2002 against the allowance for doubtful accounts.

5. Inventories

Inventories at March 31, 2003 and 2002 consisted of the following:

	2003	2002
Raw materials	\$ 1,217,033	\$ 1,545,327
Work-in-progress	2,250,321	10,046,359
Finished goods	1,650,432	1,621,145
	<u>\$ 5,117,786</u>	<u>\$ 13,212,831</u>

The Company also has long-term inventory (see Note 7). The Company recorded a charge of \$3,421,100 and \$3,464,275 for fiscal 2003 and 2002, respectively, relating to the write-down of the remaining inventory value of low temperature superconductor storage devices. These inventory reserve provisions were recorded as part of Costs of revenue – product sales and prototype development contracts.

6. Other Assets

Other assets at March 31, 2003 and 2002 consisted of the following:

	2003	2002
Licenses	\$ 1,053,248	\$ 1,148,247
Patents	5,725,055	5,715,795
Deposits	56,962	57,333
	<u>6,835,265</u>	<u>6,921,375</u>
Less: accumulated amortization	(2,127,662)	(1,444,812)
Other assets	<u>\$ 4,707,603</u>	<u>\$ 5,476,563</u>

The Company recorded patent and license amortization expense of \$1,003,495, \$620,690, and \$330,386 for fiscal years 2003, 2002, and 2001, respectively. During fiscal 2003, disposals of Licenses and Patents were \$95,000 and \$812,529, respectively, with an accumulated amortization of \$320,645, resulting in a net disposal- related change in Other assets of \$586,884. There were no disposals of Other assets in fiscal 2002 or fiscal 2001.

7. Long-term Inventory and Deferred Revenue

Long-term inventory of \$3,250,000 represents SMES units that were delivered in fiscal 2001 to one of our customers, Wisconsin Public Service Corporation (“WPS”) for a total purchase price of \$3,787,000, less \$537,000 recorded as revenue in the quarter ended December 31, 2002. As the sale of these units is subject to certain return and buyback provisions which expire from 2002 to 2009, the Company is deferring recognition of the revenue related to the remaining \$3,250,000 in sales until the applicable buyback provisions lapse. Long-term deferred revenue of \$3,250,000 represents the \$3,787,000 cash payment received from WPS related to this transaction, less \$537,000 recorded as revenue in the third quarter of fiscal 2003.

The buyback provisions, which are subject to a minimum 6-month written notice requirement, began to lapse in the quarter ended December 31, 2002, until which time WPS had the right to return all the units for the

AMERICAN SUPERCONDUCTOR CORPORATION
NOTES TO CONSOLIDATED STATEMENTS—(Continued)

full purchase price of \$3,787,000. On December 31 of each year after 2002, WPS has the right, subject to a minimum 6-month notice requirement, to sell the units back to the Company at a reduced price. Between January 1, 2003 and the next annual buyback date of December 31, 2003, the repurchase price for the units will be \$3,250,000 and that price is further reduced by approximately 12% per year through December 31, 2009.

The Company recorded \$537,000 of revenue and an equal amount of cost of revenue in the quarter ended December 31, 2002, as the buyback price transitioned from \$3,787,000 to \$3,250,000. The Company also recorded a \$537,000 reduction in long-term inventory and long-term deferred revenue.

8. Accounts Payable and Accrued Expenses

Accounts payable and accrued expenses at March 31, 2003 and 2002 consisted of the following:

	2003	2002
Accounts payable	\$ 3,721,307	\$ 12,901,332
Accrued restructuring	435,317	2,520,115
Accrued employee stock purchase plan	199,567	267,535
Accrued expenses	4,749,327	4,353,565
Accrued vacation	668,356	742,384
	<u>\$ 9,773,874</u>	<u>\$ 20,784,931</u>

9. Income Taxes

The reconciliation between the statutory federal income tax rate and the Company's effective income tax rate is shown below.

	For the Years Ended March 31,		
	2003	2002	2001
Statutory federal income tax rate	-34%	-34%	-34%
State income taxes, net federal benefit	-6%	-7%	-6%
Nondeductible expenses	0%	1%	1%
Research & development credit	0%	-2%	-3%
Valuation allowance	40%	42%	42%
Effective income tax rate	<u>0%</u>	<u>0%</u>	<u>0%</u>

The principal components of the Company's deferred tax liabilities and assets were the following:

	For the Years Ended March 31,	
	2003	2002
Deferred tax assets and (liabilities):		
Net operating loss carryforward	\$ 93,547,000	\$ 77,726,000
Research and development and other credits	3,583,000	4,454,000
Accruals and reserves	4,146,000	5,279,000
Fixed Assets and intangibles	17,475,000	(249,000)
Other	302,000	155,000
Valuation allowance	(119,053,000)	(87,365,000)
Net	<u>—</u>	<u>—</u>

AMERICAN SUPERCONDUCTOR CORPORATION
NOTES TO CONSOLIDATED STATEMENTS—(Continued)

At March 31, 2003 the Company had available for federal income tax purposes net operating loss carryforwards of approximately \$242,600,000, which expire in years 2004 through 2024. This includes approximately \$14,900,000 of acquired net operating losses from Superconductivity, Inc. (“SI”) which begin to expire in the fiscal year ending 2004, and their utilization by the Company will be subject to annual limitations. SI was acquired by the Company on April 8, 1997.

The Company has recorded a deferred tax asset of approximately \$12,666,000 reflecting the benefit of deductions from the exercise of stock options. This deferred tax asset has been fully reserved until it is more likely than not that the tax benefit from the exercise of stock options will be realized. The benefit from this \$12,666,000 will be recorded as a credit to additional paid-in capital when realized. Research and development and other credit carryforwards amounting to approximately \$4,200,000 are available to offset federal and state income taxes and expire in years 2004 through 2024. Under current tax law, the utilization of net operating loss and research and development and other tax credit carryforwards may be subject to annual limitations in the event of certain changes in ownership.

10. Stockholders’ Equity

The Offerings

On March 6, 2000 the Company completed a public offering of 3,500,000 shares of its common stock and received net proceeds (after the underwriters discount but before deducting offering expenses) of \$205,625,000. On April 22, 1998 the Company completed a public offering of 3,504,121 shares of its common stock and received net proceeds (after the underwriters discount but before deducting offering expenses) of \$46,114,000, of which approximately \$3,142,000 was used to retire the Company’s subordinated notes.

Stock Compensation Expense

The composition of stock compensation expense in the Statement of Stockholder’s Equity for the last three fiscal years was as follows:

	For the fiscal years ended March 31,		
	2003	2002	2001
401(k) Match	\$ 360,003	\$ 461,892	\$ 181,086
Employee Stock Awards	7,189	17,580	40,928
	<u>\$ 367,192</u>	<u>\$ 479,472</u>	<u>\$ 222,014</u>

Stock-Based Compensation Plans

The Company has six stock option plans including three Directors’ Plans. The stock option plans (the “Plans”) include the 1987 Stock Plan (the “1987 Plan”), the 1993 Stock Option Plan (the “1993 Plan”), the 1996 Stock Incentive Plan (the “1996 Plan”), the 1991 Director Stock Option Plan (the “1991 Director Plan”), the 1994 Director Stock Option Plan (the “1994 Director Plan”), and the Amended and Restated 1997 Director Stock Option Plan (the “1997 Director Plan”). The Board of Directors authorized the issuance of 74,000 shares of restricted stock with a fair market value of \$636,400 to certain officers in fiscal year 2000. The shares are subject to restrictions on transfers and repurchase rights in favor of the Company; the restriction on sale can be removed upon meeting certain corporate performance targets or at the end of a six-year vesting period. The Company recorded expenses of \$106,067, \$106,067, and \$106,067 for the fiscal years ended 2003, 2002 and 2001, respectively, related to this issuance. Due to officer attrition, the Company also recorded an adjustment to

AMERICAN SUPERCONDUCTOR CORPORATION
NOTES TO CONSOLIDATED STATEMENTS—(Continued)

deferred compensation in fiscal year 2003. The Board of Directors authorized an additional 31,000 shares of restricted stock in fiscal 2003 with a fair market value of \$193,440 to certain officers. The Company recorded expenses of \$32,244 in fiscal 2003 related to this issuance. Additionally, the Board of Directors authorized options for an additional 175,000 shares related to the acquisition of IE. All options issued under the IE plan are nonqualified. The Plans are administered by the Compensation Committee of the Board of Directors and permit the Company to sell or award common stock or to grant stock options for the purchase of common stock.

The Plans provide for the issuance of incentive stock options and non-qualified stock options to purchase the Company's common stock. In the case of incentive stock options, the exercise price shall be equal to at least the fair market value of the common stock, as determined by the Board of Directors, on the date of grant. The 1991, 1994 and 1997 Director Plans are stock option plans for members of the Board of Directors who are not also employees of the Company ("outside directors"). The 1997 Director Plan provides for the automatic grant of stock options for the purchase of common stock by outside directors at an exercise price equal to fair market value at the grant date. No further grants may be made under the 1987 Plan, the 1991 Director Plan or the 1994 Director Plan.

Options granted under the Plans, other than the Amended and Restated 1997 Director Stock Option Plan, generally become exercisable in equal annual increments over a four or five year period and expire 10 years from the date of grant or from two to three months after termination of employment.

The following table summarizes information about stock options outstanding at March 31, 2003.

Range of Exercise Price	Outstanding			Exercisable		
	Number Outstanding At 3/31/03	Weighted Average Remaining Contractual Life	Weighted Average Exercise Price	Number Exercisable at 3/31/03	Weighted Average Exercise Price	
\$ 0.00– 5.89	163,000	7.4	\$ 1.78	163,000	\$ 1.78	
5.89–11.78	1,600,510	6.1	9.45	884,518	10.01	
11.78–17.66	988,905	5.2	13.24	604,115	12.94	
17.66–23.55	439,750	2.1	20.66	390,950	20.58	
23.55–29.44	622,750	6.0	26.04	257,740	26.03	
29.44–35.33	750,000	7.3	32.56	300,000	32.56	
35.33–41.21	65,000	6.5	36.79	26,000	36.79	
41.21–58.88	40,000	6.9	58.88	30,000	58.88	
\$ 0.00–58.88	4,669,915	5.8	\$ 17.77	2,656,323	\$ 16.64	

AMERICAN SUPERCONDUCTOR CORPORATION
NOTES TO CONSOLIDATED STATEMENTS—(Continued)

The following table summarizes the information concerning currently outstanding and exercisable options:

	Shares	Weighted average Exercise Price	Number Exercisable
Outstanding at March 31, 2000	3,464,721	\$ 12.86	1,398,191
Granted	1,703,200	29.33	
Exercised	(490,068)	11.61	
Canceled	(91,044)	14.48	
Outstanding at March 31, 2001	4,586,809	18.93	1,515,347
Granted	857,050	13.30	
Exercised	(75,166)	9.59	
Canceled	(416,153)	14.35	
Outstanding at March 31, 2002	4,952,540	18.51	2,235,801
Granted	524,300	6.76	
Exercised	(0)	0.00	
Canceled	(806,925)	15.16	
Outstanding at March 31, 2003	4,669,915	\$ 17.77	2,656,323
Available for grant at March 31, 2003		1,414,205	

Stock Purchase Warrants

The Company recorded an increase to additional paid-in capital and a corresponding charge to deferred warrant costs of approximately \$336,000 in January 1998 related to the issuance of stock purchase warrants for 250,500 shares of common stock at an exercise price of \$10.20 per share which were exercisable over a five-year period following the date of grant. These warrants, which were not exercised, were granted in consideration of ongoing financial services being provided to the Company. Expense related to these warrants was approximately \$50,000, \$67,000 and \$67,000 for the fiscal years ended March 31, 2003, 2002 and 2001, respectively.

The Company also granted warrants in 1996 and 1998 to the Electric Power Research Institute (EPRI). See Note 12.

11. Commitments

The Company rents its headquarters in Westborough, MA, under an operating lease, which expires in May 2009. In October 2000 the Company leased additional facilities in Westborough for the development of electric motor and generator technology under an operating lease that expires in 2005. The Company also rents an operating facility near Madison, WI, under a lease which expires on December 31, 2004, and one facility near Milwaukee, WI, under a lease which expires in 2011. The Company has an option to extend the Madison, WI lease for an additional three or five-year period. As part of its restructuring, consolidation and cost cutting measures announced in March 2002, the Company is outsourcing requirements for low temperature superconductor (LTS) magnets used in its SMES systems and as a result ceased operations in one of its two buildings in Middleton, WI, comprising approximately 27,000 square feet. Under all leases, the Company pays for real estate taxes, certain insurance coverage and operating expenses.

Rent expense under the leases mentioned above was as follows:

	2003	2002	2001
Rent expense	\$ 2,043,000	\$ 1,994,000	\$ 1,435,000

AMERICAN SUPERCONDUCTOR CORPORATION
NOTES TO CONSOLIDATED STATEMENTS—(Continued)

Minimum future lease commitments at March 31, 2003 were as follows:

<u>For the years ended March 31,</u>	<u>Total</u>
2004	\$ 2,855,298
2005	2,881,441
2006	2,726,578
2007	2,612,257
2008	2,792,619

In September 2002, the Company entered into a standby letter of credit arrangement with a financial institution to provide a guarantee for rent of \$1,000,000 for the Two Technology Drive facility in Westborough, Massachusetts. The letter of credit amount may be reduced to \$750,000 at June 1, 2005 and to \$500,000 at June 1, 2007. This letter of credit will expire on July 31, 2009.

As permitted under Delaware law, we have agreements whereby we indemnify our officers and directors for certain events or occurrences while the officer or director is, or was serving, at our request in such capacity. The term of the indemnification period is for the officer's or director's lifetime. The maximum potential amount of future payments we could be required to make under these indemnification agreements is unlimited; however, we have a Director and Officer insurance policy that limits our exposure and enables us to recover a portion of any future amounts paid. As a result of our insurance policy coverage, we believe the estimated fair value of these indemnification agreements is minimal. All of these indemnification agreements were grandfathered under the provisions of FIN No. 45 as they were in effect prior to March 31, 2003. Accordingly, we have no liabilities recorded for these agreements as of March 31, 2003.

12. Research and Development Agreements

The Company signed an agreement with Pirelli in February 2002 giving the Company the right to sell HTS wire to other cable manufacturers in addition to Pirelli in exchange for a \$2,250,000 one-time license payment, 50,000 shares of its stock (valued at \$6.91 per share), royalties on future such sales of wire, and the forgiveness of \$1,375,000 of accounts receivable. The agreement discontinued Pirelli's funding of the Company's research and development effective January 1, 2002. Under the previous agreement, Pirelli provided the Company with \$500,000 per quarter in research and development funding. Pirelli will, however, continue its participation in the Company's multi-filamentary composite wire product development programs through September 2003. The Pirelli alliance was originally established in February 1990; in the 12-year period between 1990 and March 31, 2002, the Company received development funding of approximately \$23,100,000 from Pirelli. The Company recorded revenues under this contract of \$0, \$1,500,000 and \$2,000,000 in fiscal years ended March 31, 2003, 2002 and 2001, respectively.

In March 1996, the Company entered into a strategic alliance with the Electric Power Research Institute (EPRI) to develop and commercialize a coated conductor composite HTS wire. This agreement ended on March 31, 2000. In March 1996, under the first phase of the agreement, the Company granted a warrant for 100,000 shares of common stock (87,500 of which have been exercised) to EPRI at \$14.00 per share which became exercisable over a five-year period following the date of grant. In March 1998, under the second phase of the agreement, the Company granted to EPRI another warrant to purchase 110,000 shares of common stock (41,250 of which have been exercised) of the Company at \$13.94 per share, which became exercisable over a five-year period. The Company has received exclusive license rights to intellectual property from EPRI. The Company recorded an increase to additional paid-in capital and a corresponding charge to deferred contract costs of \$618,000 and \$637,000 in fiscal 1998 and 1997, respectively, relating to these warrants. Warrant expense related to these agreements was approximately \$71,000, \$148,000, and \$234,000 for the fiscal years ended March 31, 2003, 2002 and 2001, respectively.

AMERICAN SUPERCONDUCTOR CORPORATION
NOTES TO CONSOLIDATED STATEMENTS—(Continued)

13. Cost Sharing Arrangements

The Company has entered into several cost-sharing arrangements with various agencies of the United States government. Funds paid to the Company under these agreements are not reported as revenues but are used to directly offset the Company's research and development and selling, general and administrative expenses, and to purchase capital equipment. The Company recorded costs and funding under these agreements of \$1,820,000 and \$764,000, respectively, for fiscal 2003, of \$1,206,000 and \$603,000, respectively, for fiscal 2002, and of \$645,000 and \$262,000, respectively, for fiscal 2001. At March 31, 2003, total funding received to date under these agreements was \$14,178,000. Future funding expected to be received under existing agreements is approximately \$2,066,000 subject to continued future funding allocations.

14. Employee Benefit Plans

The Company has implemented a deferred compensation plan under Section 401(k) of the Internal Revenue Code. Any contributions by the Company are discretionary. The company instituted a stock match program in July 1998 under which the Company matched 25% of the first 4% of eligible contributions to the plan. Effective July 1, 2000 this contribution increased to 25% of the first 6% of eligible contributions. Effective July 1, 2001 this contribution increased to 35% of the first 6% of eligible contributions. The Company recorded expense of \$360,003, \$437,401, and \$234,472 in fiscal years 2003, 2002 and 2001, respectively, and corresponding charges to additional paid-in capital related to this program. The Company does not have post-retirement or post-employment benefit plans.

The Company instituted an employee stock purchase plan ("ESPP") on October 1, 2000. Employees purchase shares at a discount from fair market value every six months; this is a noncompensatory plan and accordingly no expense was recognized by the Company. Shares issued are recorded under "Issuance of Common Stock" in the Consolidated Statements of Stockholders Equity.

15. Impairment of Long-lived Assets

In the fourth quarter of fiscal 2003, in accordance with SFAS 144, the Company recorded charges totaling \$39.2 million for impairment of the group of long-lived assets associated with the AMSC Wires business segment, specifically the Devens wire manufacturing plant, the capital equipment in that plant, and first generation (1G) wire-related patents.

A number of factors indicated a potential impairment of the asset group, including substantial operating losses incurred and projected future losses associated with the AMSC Wires business segment, the Company's intent to transition to the manufacture of second generation (2G) wire within the next several years and the Company's market capitalization being less than the net book value for a significant period. In the fourth quarter of fiscal 2003, the Company revised its analysis of the probable timing of the transition to 2G wire, determining that the transition would be accelerated over previous expectations. The acceleration of the timing of the transition was the principal factor indicating a potential impairment.

To determine whether the asset group was impaired, the Company used a probability-weighted multiple scenario cash flow approach based on four potential scenarios that reflected a range of possible outcomes. The estimates used for future cash flows were based on producing and selling only 1G wire and excluded any costs or revenues that would be generated as a result of the transition to 2G wire. The success and timing for transitioning to a 2G wire manufacturing process remain uncertain. This uncertainty impacted the range of possible cash flow outcomes. The scenarios ranged from a long-term delay of the transition to 2G wire to successful introduction of 2G wire on an accelerated time-line. The Company believes that the most likely scenario is a successful transition to the 2G wire manufacturing process in the next few years.

AMERICAN SUPERCONDUCTOR CORPORATION
NOTES TO CONSOLIDATED STATEMENTS—(Continued)

On the basis of the probability-weighted cash flow analysis, the Company determined that the asset group was impaired and utilized a probability-weighted discounted cash flow as the best estimate of the fair value of the asset group. An impairment charge of \$39.2 million was recorded to write down the asset group to its estimated fair value.

In allocating the \$39.2 million impairment charge across the individual assets, the Company used an independent appraisal of the value of the property and plant as the current fair value for this asset, and assigned the remainder of the impairment charge on a pro rata basis between equipment and patents.

Summary of Impairment Charge

Building	\$ 17,642,105
Equipment	\$ 21,217,734
Patents (Other Assets)	\$ 371,038
	<hr/>
Total Impairment	\$ 39,230,877
	<hr/>

In conjunction with the impairment, the Company also reviewed and shortened the depreciable lives on the remaining net book value of the wires manufacturing equipment from ten to six years.

16. Restructuring/Pirelli/Other Charges (Fiscal 2002)

Workforce Reduction

In March of fiscal 2002, a restructuring program resulted in the reduction of 99 full-time employees across all business functions at the Company's Massachusetts and Wisconsin locations. The workforce reductions were substantially completed in the fourth quarter of fiscal 2002, although nine affected employees were part of the Company's reported headcount as of March 31, 2002. The Company recorded a workforce reduction charge of \$1,548,897 relating primarily to severance and related benefits.

Consolidation of Facilities

In fiscal 2002, the Company recorded a charge of \$4,117,161 relating to the consolidation of the Company's Power Quality and Reliability business unit based in Middleton, WI with its Power Electronics business unit based in New Berlin, WI, into one new business unit called Power Electronic Systems. The total charge includes \$2,826,403 related to the write-off of fixed assets and \$691,100 for a facility lease termination in Middleton, WI. The balance of \$599,658 relates to cancelled purchase commitments. All such costs were recorded as restructuring costs.

Pirelli License Costs

In fiscal 2002, the Company recorded a charge of \$4,009,890 relating to the announcement of a license agreement with Pirelli to allow the Company to sell its HTS wire to other cable manufacturers in addition to Pirelli. The \$4,009,890 charge is shown as "Pirelli license costs" on the Consolidated Statements of Operations and is comprised of a \$2,250,000 cash license payment, 50,000 shares of the Company's common stock (valued at \$6.91 per share) that were issued in fiscal 2003, and the forgiveness of \$1,375,000 of accounts receivable.

AMERICAN SUPERCONDUCTOR CORPORATION
NOTES TO CONSOLIDATED STATEMENTS—(Continued)

The restructuring charges and other charges recorded in the fourth quarter of fiscal 2002 are summarized below:

	Total Restructuring & other charges	Cash Payments	Other Adjustments	Balance as of March 31, 2003
Workforce Reduction	\$ 1,548,897	\$ 1,548,897	\$ —	\$ —
Consolidation of facilities, fixed asset write-offs, & other charges	4,117,161	498,039	3,144,409	474,713
Inventory Write-down	3,464,275	—	2,212,456	1,251,819
Allowance for Doubtful Accounts	727,028	—	727,028	—
Pirelli License	4,009,890	2,289,390	1,720,500	—
	\$ 13,867,251	\$ 4,336,326	\$ 7,804,393	\$ 1,726,532

Cash payments for the restructuring activities and other charges were completed within fiscal 2003, except for certain long-term contractual obligations such as the Middleton, WI facility lease payments through the end of third quarter of fiscal 2004. Of the remaining balance of \$1,726,532, \$474,713 is expected to be paid out in cash.

The inventory write-down and allowance for doubtful accounts charges were classified as “Costs of revenue—product sales and prototype development contracts” and “Selling, general and administrative” expense, respectively, not as restructuring charges.

17. Business Segment Information

The Company has three reportable business segments—AMSC Wires, SuperMachines, and the Power Electronic Systems.

The AMSC Wires (formerly known as HTS Wire) business segment develops and sells HTS wire. The focus of this segment’s current development, manufacturing and sales efforts is on HTS wire for power transmission cables, motors, generators, synchronous condensers and specialty magnets.

The SuperMachines (formerly known as Electric Motors and Generators) business segment is developing and commercializing electric motors, generators, and synchronous condensers based on HTS wire. Its primary focus, for motors and generators, is on ship propulsion.

The Power Electronic Systems business segment develops and sells power electronic converters and designs, manufactures and sells integrated systems based on those converters for power quality and reliability solutions and for wind farm applications.

The operating results for the three business segments are as follows:

Revenues*	Fiscal Year Ended March 31		
	2003	2002	2001
AMSC Wires	\$ 3,960,823	\$ 4,394,285	\$ 4,945,140
SuperMachines	6,125,151	5,839,895	2,507,399
Power Electronic Systems	10,934,318	1,415,920	9,314,985
Total	\$ 21,020,292	\$ 11,650,100	\$ 16,767,524

* See footnote 13. Cost share funding is not included in reported revenues.

AMERICAN SUPERCONDUCTOR CORPORATION
NOTES TO CONSOLIDATED STATEMENTS—(Continued)

<u>Operating (loss)</u>	<u>Fiscal Year Ended March 31</u>		
	<u>2003</u>	<u>2002</u>	<u>2001</u>
AMSC Wires	\$(66,727,224)	\$(26,143,475)	\$(17,648,181)
SuperMachines	(7,475,982)	(7,747,637)	(8,209,870)
Power Electronic Systems	(12,990,785)	(25,818,528)	(6,943,149)
Unallocated corporate expenses	(1,317,494)	(1,843,204)	(1,594,368)
Total	\$(88,511,485)	\$(61,552,844)	\$(34,395,568)

The assets for the three business segments (plus Corporate cash) are as follows:

	<u>Fiscal Year Ended March 31,</u>	
	<u>2003</u>	<u>2002</u>
AMSC Wires	\$ 66,393,042	\$ 102,010,166
SuperMachines	4,992,328	6,424,532
Power Electronic Systems	10,544,397	21,160,616
Corporate cash and marketable securities	20,048,872	68,199,610
Total	\$ 101,978,639	\$ 197,794,924

Other significant segment information is as follows:

<u>Depreciation and amortization</u>	<u>Fiscal Year Ended March 31,</u>		
	<u>2003</u>	<u>2002</u>	<u>2001</u>
AMSC Wires	\$ 6,709,830	\$ 3,776,152	\$ 2,813,963
SuperMachines	571,967	593,545	281,396
Power Electronic Systems	820,339	1,139,346	1,003,545
Total	\$ 8,102,136	\$ 5,509,043	\$ 4,098,904

<u>Capital expenditures</u>	<u>Fiscal Year Ended March 31,</u>	
	<u>2003</u>	<u>2002</u>
AMSC Wires	\$ 7,599,488	\$ 60,694,504
SuperMachines	66,835	373,174
Power Electronic Systems	132,912	2,054,498
Total	\$ 7,799,235	\$ 63,122,176

The accounting policies of the business segments are the same as those described in Note 2, except that certain corporate expenses which we do not believe are specifically attributed or allocable to either business segment have been excluded from the segment operating loss.

AMERICAN SUPERCONDUCTOR CORPORATION
NOTES TO CONSOLIDATED STATEMENTS—(Continued)

18. Quarterly Financial Data (Unaudited)

Three Months Ended	Fiscal year ended March 31, 2003:			
	June 30, 2002	September 30, 2002	December 31, 2002	March 31, 2003 *
Total Revenues	\$ 2,860,000	\$ 4,480,000	\$ 2,751,000	\$ 10,929,000
Operating (loss)	\$(11,180,000)	\$(10,502,000)	\$(12,805,000)	\$(54,024,000)
Net loss	\$(10,829,000)	\$(10,222,000)	\$(12,615,000)	\$(53,967,000)
Net loss per common share	\$ (0.53)	\$ (0.50)	\$ (0.60)	\$ (2.54)

Three Months Ended	Fiscal year ended March 31, 2002:			
	June 30, 2002	September 30, 2002	December 31, 2002	March 31, 2003 *
Total Revenues	\$ 1,659,000	\$ 3,257,000	\$ 3,533,000	\$ 3,201,000
Operating (loss)	\$(11,072,000)	\$(10,473,000)	\$(11,545,000)	\$(28,463,000)
Net loss	\$ (9,044,000)	\$ (9,116,000)	\$(10,884,000)	\$(27,941,000)
Net loss per common share	\$ (0.44)	\$ (0.45)	\$ (0.53)	\$ (1.36)

* See discussion on impairment and other charges in footnote 15.

19. New Accounting Pronouncements

In June 2002, the Financial Accounting Standards Board (FASB) issued Statement of Financial Accounting Standards (SFAS) No. 146, "Accounting for Costs Associated with Exit or Disposal Activities" ("SFAS No. 146"). This statement addresses financial accounting and reporting for costs associated with exit or disposal activities and nullifies EITF Issue No. 94-3, "Liability Recognition for Certain Employee Termination Benefits and Other Costs to Exit an Activity (including Certain Costs Incurred in a Restructuring)" ("EITF 94-3"). SFAS No. 146 requires that a liability for a cost associated with an exit or disposal activity be recognized when the liability is incurred. EITF 94-3 allowed for an exit cost liability to be recognized at the date of an entity's commitment to an exit plan. SFAS 146 also requires that liabilities recorded in connection with exit plans be initially measured at fair value. The provisions of SFAS 146 are effective for exit or disposal activities that are initiated after December 31, 2002, with early adoption encouraged. The Company does not expect the adoption of SFAS 146 to have a material impact on its financial position or results of operations.

In November 2002, the FASB issued FASB Interpretation No. 45 (FIN 45) "Guarantor's Accounting and Disclosure Requirements for Guarantees, including Indirect Guarantees of Indebtedness of Others—an interpretation of FASB Statements No. 5, 57 and 107 and rescission of FASB Interpretation No. 34." FIN 45 clarifies that a guarantor is required to recognize, at the inception of the guarantee, a liability for the fair value of the obligation undertaken in issuing certain guarantees. FIN 45 also requires additional disclosures to be made by a guarantor in its interim and annual financial statements about its obligations under certain guarantees it has issued. The accounting requirements for the initial recognition of guarantees are applicable on a prospective basis for guarantees issued or modified after December 31, 2002. The disclosure requirements are effective for all guarantees outstanding, regardless of when they were issued or modified, beginning with periods ending after December 15, 2002. The Company has applied the disclosure provisions of FIN 45 as of December 31, 2002, as required. The adoption of FIN 45 did not have a material effect on the Company's consolidation financial statements for the year end March 31, 2003.

On December 31, 2002, the FASB issued SFAS 148, "Accounting for Stock-Based Compensation—Transition and Disclosure." SFAS 148 amends SFAS 123, "Accounting for Stock-Based Compensation," to provide alternative methods of transition for a voluntary change to the fair value based method of accounting for

[Table of Contents](#)

stock-based employee compensation. In addition, SFAS 148 amends the disclosure requirements of SFAS 123 to require prominent disclosures in both annual and interim financial statements about the method of accounting for stock-based employee compensation and the effect of the method used on reported results. The transition and annual disclosure provisions are effective for fiscal years ending after December 15, 2002. The new interim disclosure provisions are effective for the first interim period beginning after December 15, 2002. The Company has complied with the disclosure requirements of SFAS 148.

In January 2003, the FASB issued FASB Interpretation No. 46 (FIN 46), "Consolidation of Variable Interest Entities." In general, a variable interest entity is a corporation, partnership, trust or any other legal structure used for business purposes that either (a) does not have equity investors with voting rights or (b) has equity investors that do not provide sufficient financial resources for the entity to support its activities. A variable interest entity often holds financial assets, including loans or receivables, real estate or other property. Variable interest entities have been commonly referred to as special-purpose entities or off-balance sheet structures. This Interpretation requires a variable interest entity to be consolidated by a company if that company is subject to a majority of the risk of loss from the variable interest entity's activities or entitled to receive a majority of the entity's residual returns or both. The Company does not expect that this Interpretation will have a material impact on its financial position or results of operations.

American Superconductor Corporation
Schedule II—Valuation and Qualifying Accounts

<u>Description</u>	<u>Balance, Beginning of Year</u>	<u>Additions Charged to Costs and Expenses</u>	<u>Deductions Actual Write-Off</u>	<u>Less Recoveries</u>	<u>Balance, End of Year</u>
Allowance for doubtful notes and accounts receivable:					
Year ended March 31, 2003	\$ 42,000	\$ 2,650,398	\$ 34,913	\$ —	\$ 2,657,485
Year ended March 31, 2002	71,187	727,028	756,215	—	42,000
Year ended March 31, 2001	—	71,187	—	—	71,187

REPORT OF INDEPENDENT ACCOUNTANTS

To the Board of Directors and Shareholders of American Superconductor Corporation:

Our audits of the consolidated financial statements referred to in our report dated June 27, 2003 also included an audit of the financial statement schedule for the three years ended March 31, 2003 noted in Item 15(a)(2) of this Form 10-K. In our opinion, this financial statement schedule for the three years ended March 31, 2003 presents fairly, in all material respects, the information set forth therein when read in conjunction with the related consolidated financial statements.

A handwritten signature in black ink that reads "PricewaterhouseCoopers LLP". The signature is written in a cursive, flowing style.

Boston, Massachusetts
June 27, 2003

CERTIFICATIONS

I, Gregory J. Yurek, certify that:

1. I have reviewed this annual report on Form 10-K of American Superconductor Corporation;
2. Based on my knowledge, this annual report does not contain any untrue statement of a material fact or omit to state a material fact necessary to make the statements made, in light of the circumstances under which such statements were made, not misleading with respect to the period covered by this annual report;
3. Based on my knowledge, the financial statements, and other financial information included in this annual report, fairly present in all material respects the financial condition, results of operations and cash flows of the registrant as of, and for, the periods presented in this annual report;
4. The registrant's other certifying officer and I are responsible for establishing and maintaining disclosure controls and procedures (as defined in Exchange Act Rules 13a-14 and 15d-14) for the registrant and have:
 - a) designed such disclosure controls and procedures to ensure that material information relating to the registrant, including its consolidated subsidiaries, is made known to us by others within those entities, particularly during the period in which this annual report is being prepared;
 - b) evaluated the effectiveness of the registrant's disclosure controls and procedures as of a date within 90 days prior to the filing date of this annual report (the "Evaluation Date"); and
 - c) presented in this annual report our conclusions about the effectiveness of the disclosure controls and procedures based on our evaluation as of the Evaluation Date;
5. The registrant's other certifying officer and I have disclosed, based on our most recent evaluation, to the registrant's auditors and the audit committee of registrant's board of directors (or persons performing the equivalent functions):
 - a) all significant deficiencies in the design or operation of internal controls which could adversely affect the registrant's ability to record, process, summarize and report financial data and have identified for the registrant's auditors any material weaknesses in internal controls; and
 - b) any fraud, whether or not material, that involves management or other employees who have a significant role in the registrant's internal controls; and
6. The registrant's other certifying officer and I have indicated in this annual report whether there were significant changes in internal controls or in other factors that could significantly affect internal controls subsequent to the date of our most recent evaluation, including any corrective actions with regard to significant deficiencies and material weaknesses.

/s/ GREGORY J. YUREK

Gregory J. Yurek
Chief Executive Officer, President,
Chairman of the Board
(Principal Executive Officer)

Dated: June 30, 2003

CERTIFICATIONS

I, Kevin Bisson, certify that:

1. I have reviewed this annual report on Form 10-K of American Superconductor Corporation;
2. Based on my knowledge, this annual report does not contain any untrue statement of a material fact or omit to state a material fact necessary to make the statements made, in light of the circumstances under which such statements were made, not misleading with respect to the period covered by this annual report;
3. Based on my knowledge, the financial statements, and other financial information included in this annual report, fairly present in all material respects the financial condition, results of operations and cash flows of the registrant as of, and for, the periods presented in this annual report;
4. The registrant's other certifying officer and I are responsible for establishing and maintaining disclosure controls and procedures (as defined in Exchange Act Rules 13a-14 and 15d-14) for the registrant and have:
 - a) designed such disclosure controls and procedures to ensure that material information relating to the registrant, including its consolidated subsidiaries, is made known to us by others within those entities, particularly during the period in which this annual report is being prepared;
 - b) evaluated the effectiveness of the registrant's disclosure controls and procedures as of a date within 90 days prior to the filing date of this annual report (the "Evaluation Date"); and
 - c) presented in this annual report our conclusions about the effectiveness of the disclosure controls and procedures based on our evaluation as of the Evaluation Date;
5. The registrant's other certifying officer and I have disclosed, based on our most recent evaluation, to the registrant's auditors and the audit committee of registrant's board of directors (or persons performing the equivalent functions):
 - a) all significant deficiencies in the design or operation of internal controls which could adversely affect the registrant's ability to record, process, summarize and report financial data and have identified for the registrant's auditors any material weaknesses in internal controls; and
 - b) any fraud, whether or not material, that involves management or other employees who have a significant role in the registrant's internal controls; and
6. The registrant's other certifying officer and I have indicated in this annual report whether there were significant changes in internal controls or in other factors that could significantly affect internal controls subsequent to the date of our most recent evaluation, including any corrective actions with regard to significant deficiencies and material weaknesses.

/s/ KEVIN BISSON

Kevin Bisson
Senior Vice President and Chief Financial Officer
(Principal Financial Officer)

Dated: June 30, 2003

EXHIBIT INDEX

<u>Exhibit No.</u>	<u>Description</u>
3.1	Restated Certificate of Incorporation of the Registrant (1)
3.2	Amended and Restated By-laws of the Registrant (2)
4.1	Specimen Certificate for shares of Common Stock, \$.01 par value, of the Registrant (3)
4.2	Rights Agreement dated as of October 30, 1998 between the Registrant and American Stock Transfer & Trust Company, as Rights Agent (4)
4.3	Amendment No. 1 to Rights Agreement dated as of January 29, 1999 between the Registrant and American Stock Transfer & Trust Company, as Rights Agent (5)
*10.1	Employment Agreement dated as of December 4, 1991 between the Registrant and Gregory J. Yurek (3)
*10.2	Employment Agreement dated as of December 4, 1991 between the Registrant and Alexis P. Malozemoff (3)
10.3	Form of Employee Nondisclosure and Developments Agreement (3)
*10.4	Employee Nondisclosure and Developments Agreement dated as of December 26, 1990 between the Registrant and Alexis P. Malozemoff (3)
*10.5	Noncompetition Agreement dated as of July 10, 1987 between the Registrant and John Vander Sande (3)
†10.6	License Agreement between the Registrant and MIT dated as of July 6, 1987 (3)
†10.7	License Agreement between the Registrant and MIT dated as of January 31, 1989 (3)
†10.8	License Agreement dated as of August 1, 1991 (3)
†10.9	License Agreement dated as of September 1, 1991 (3)
†10.10	Second Amendment dated as of January 27, 1992 between the Registrant and MIT amending the License Agreement dated as of July 6, 1987 between the Registrant and MIT (6)
†10.11	Technology Development and Patent Licensing Agreement dated October 7, 1992 among the Registrant and Electricity Corporation of New Zealand Limited and Industrial Research Limited (7)
*10.12	Employment Agreement dated as of December 31, 1992 between American Superconductor Europe GmbH and Dr. Gero Papst (7)
10.13	Lease dated March 9, 1993 between CGLIC on Behalf of its Separate Account R, as Landlord, and the Registrant (7)
10.14	First Amendment to Lease between CGLIC, on Behalf of its Separate Account R, as Landlord, and the Registrant, as Tenant dated October 27, 1993 (8)
*10.15	1993 Stock Option Plan (7)
10.16	Agreement dated January 1, 1994 between Pirelli Cavi S.p.A. and the Registrant (9)
†10.17	Agreement between Pirelli Cavi S.p.A. and the Registrant, dated October 1, 1995 (10)
10.18	Technology Development and Patent Licensing Agreement, First Amendment dated August 7, 1993 among the Registrant and Electricity Corporation of New Zealand and Industrial Research Limited (8)
10.19	Subcontract Agreement effective as of September 30, 1993 by and between the Registrant and Reliance Electric Company (11)
†10.20	Fourth Amendment dated May 15, 1995 to the Exclusive License Agreement between the Registrant and MIT dated July 6, 1987 (12)

Table of Contents

<u>Exhibit No.</u>	<u>Description</u>
*10.21	Amended and Restated 1996 Stock Incentive Plan (13)
†10.22	Management Agreement between Electric Power Research Institute, Inc. and the Registrant, effective January 1, 1996 (10)
†10.23	Technology License Agreement between Electric Power Research Institute, Inc. and the Registrant, effective January 1, 1996 (10)
†10.24	Warrant granted to Electric Power Research Institute, Inc. by the Registrant, dated March 26, 1996 (10)
10.25	Strategic Alliance Agreement by and among the Registrant and CHARTH (Compagnie Holding D'Applications Et De Realisations Thermiques Et Hydrauliques), dated as of April 1, 1997 (14)
†10.26	Patent License Agreement between Lucent Technologies Inc. and the Registrant, dated as of March 31, 1998 (15)
†10.27	Agreement dated April 1, 1997 by and between Electricite de France and the Registrant (15)
†10.28	Agreement effective April 1, 1997 by and between ABB Transmission & Distribution Technology Ltd. and the Registrant (15)
†10.29	1999 Program Addendum between Pirelli Cavi e Sistemi S.p.A and the Registrant dated as of October 1, 1999 (16)
†10.30	Pirelli Cable Wire Agreement between Pirelli Cavi e Sistemi S.p.A. and the Registrant, dated as of December 31, 2001 (17)
10.31	Third Amendment to Lease for 2 Technology Drive, Westboro, MA between Gateway Sherwood, Inc. (successor in interest to CGLIC, on behalf of its Separate Account R, as Landlord), and the Registrant, dated as of August 24, 2001 (17)
*10.32	Second Amended and Restated 1997 Director Stock Option Plan (18)
21.1	Subsidiaries
23.1	Consent of PricewaterhouseCoopers LLP
99.1	Certifications Pursuant to 18 U.S.C. Section 1350, as Adopted Pursuant to Section 906 of the Sarbanes-Oxley Act of 2002

- (1) Incorporated by reference to Exhibits to the Registrant's Registration Statement on Form S-3, as amended (File No. 333-95261).
- (2) Incorporated by reference to Exhibits to the Registrant's Quarterly Report on Form 10-Q filed with the Commission on November 14, 2000 (Commission File No. 000-19672).
- (3) Incorporated by reference to Exhibits to the Registrant's Registration Statement on Form S-1, as amended (File No. 33-43647).
- (4) Incorporated by reference to Exhibit to the Registrant's Registration Statement on Form 8-A filed with the Commission on November 2, 1998 (Commission File No. 000-19672).
- (5) Incorporated by reference to Exhibit to the Registrant's Registration Statement on Form 8-A/A filed with the Commission on March 12, 1999 (Commission File No. 000-19672).
- (6) Incorporated by reference to Exhibits to the Registrant's Annual Report on Form 10-K filed with the Commission on June 29, 1992 (Commission File No. 000-19672).
- (7) Incorporated by reference to Exhibits to the Registrant's Annual Report on Form 10-K filed with the Commission on June 29, 1993 (Commission File No. 000-19672).
- (8) Incorporated by reference to Exhibits to the Registrant's Quarterly Report on Form 10-Q filed with the Commission on January 26, 1994 (Commission File No. 000-19672).
- (9) Incorporated by reference to Exhibits to Amendment No. 1 to the Registrant's Quarterly Report on Form 10-Q/A filed with the Commission on March 28, 1994 (Commission File No. 000-19672).

Table of Contents

- (10) Incorporated by reference to Exhibits to the Registrant's Annual Report on Form 10-K/A filed with the Commission on March 10, 1997 (Commission File No. 000-19672).
 - (11) Incorporated by reference to Exhibits to the Registrant's Annual Report on Form 10-K filed with the Commission on June 29, 1994 (Commission File No. 000-19672).
 - (12) Incorporated by reference to Exhibits to the Registrant's Annual Report on Form 10-K filed with the Commission on June 29, 1995 (Commission File No. 000-19672).
 - (13) Incorporated by reference to Exhibits to the Registrant's Annual Report on Form 10-K filed with the Commission on June 27, 2001 (Commission File No. 000-19672).
 - (14) Incorporated by reference to Exhibits to the Registrant's Annual Report on Form 10-K filed with the Commission on June 30, 1997 (Commission File No. 000-19672).
 - (15) Incorporated by reference to Exhibits to the Registrant's Annual Report on Form 10-K filed with the Commission on June 26, 1998 (Commission File No. 000-19672).
 - (16) Incorporated by reference to Exhibits to the Registrant's Current Report on Form 8-K filed with the Commission on January 24, 2000 (Commission File No. 000-19672).
 - (17) Incorporated by reference to Exhibits to the Registrant's Annual Report on Form 10-K filed with the Commission on June 25, 2002 (Commission File No. 000-19672).
 - (18) Incorporated by reference to Exhibits to the Registrant's Quarterly Report on Form 10-Q filed with the Commission on August 14, 2002 (Commission File No. 000-19672).
- † Confidential treatment previously requested and granted with respect to certain portions, which portions were omitted and filed separately with the Commission.
- * Management contract or compensatory plan or arrangement required to be filed as an Exhibit to this Form 10-K.

Subsidiaries

1. American Superconductor Europe GmbH (*) - established in Germany
2. ASC Devens LLC (*) - incorporated in Delaware
3. ASC Securities Corp. (*) - incorporated in Massachusetts
4. Superconductivity, Inc. (*) - incorporated in Delaware

* Wholly owned subsidiary of American Superconductor Corporation

CONSENT OF INDEPENDENT ACCOUNTANTS

We hereby consent to the incorporation by reference in the Registration Statements on Form S-8 (File Nos. 33-44962, 33-44963, 33-64832, 33-74418, 33-86106, 33-86108, 333-39653, 333-37163, 333-71539 and 333-58016) of American Superconductor Corporation of our report dated June 27, 2003 relating to the financial statements, which appears in this Annual Report on Form 10-K. We also consent to the incorporation by reference of our report dated June 27, 2003 relating to the financial statement schedule, which appears in this Form 10-K.

/s/ PricewaterhouseCoopers LLP
Boston, Massachusetts
June 30, 2003

**CERTIFICATION PURSUANT TO
18 U.S.C. SECTION 1350,
AS ADOPTED PURSUANT TO
SECTION 906 OF THE SARBANES-OXLEY ACT OF 2002**

In connection with the Annual Report on Form 10-K of American Superconductor Corporation (the "Company") for the period ended March 31, 2003 as filed with the Securities and Exchange Commission on the date hereof (the "Report"), the undersigned, Gregory J. Yurek, Chief Executive Officer of the Company, hereby certifies, pursuant to 18 U.S.C. Section 1350, as adopted pursuant to Section 906 of the Sarbanes-Oxley Act of 2002, that:

- (1) The Report fully complies with the requirements of section 13(a) or 15(d) of the Securities Exchange Act of 1934; and
- (2) The information contained in the Report fairly presents, in all material respects, the financial condition and results of operations of the Company.

A signed original of this written statement required by Section 906, or other document authenticating, acknowledging, or otherwise adopting the signature that appears in typed form within the electronic version of this written statement required by Section 906, has been provided to American Superconductor Corporation and will be retained by American Superconductor Corporation and furnished to the Securities and Exchange Commission or its staff upon request.

/s/ GREGORY J. YUREK
Gregory J. Yurek
Chief Executive Officer

June 30, 2003

**CERTIFICATION PURSUANT TO
18 U.S.C. SECTION 1350,
AS ADOPTED PURSUANT TO
SECTION 906 OF THE SARBANES-OXLEY ACT OF 2002**

In connection with the Annual Report on Form 10-K of American Superconductor Corporation (the "Company") for the period ended March 31, 2003 as filed with the Securities and Exchange Commission on the date hereof (the "Report"), the undersigned, Kevin Bisson, Chief Financial Officer of the Company, hereby certifies, pursuant to 18 U.S.C. Section 1350, as adopted pursuant to Section 906 of the Sarbanes-Oxley Act of 2002, that:

- (1) The Report fully complies with the requirements of section 13(a) or 15(d) of the Securities Exchange Act of 1934; and
- (2) The information contained in the Report fairly presents, in all material respects, the financial condition and results of operations of the Company.

A signed original of this written statement required by Section 906, or other document authenticating, acknowledging, or otherwise adopting the signature that appears in typed form within the electronic version of this written statement required by Section 906, has been provided to American Superconductor Corporation and will be retained by American Superconductor Corporation and furnished to the Securities and Exchange Commission or its staff upon request.

/s/ KEVIN BISSON
Kevin Bisson
Chief Financial Officer

June 30, 2003